

# R454b Refrigerant

# SUBMITTAL DATA SHEET



Series Name: Extreme Heat AHU Series  
Model Number: MAUSE-H48B-2A/MO1HE-H48B-2A

### Air Handler Heat Pump System

Location:	Approval:
Engineer:	Date:
Submitted to:	Construction:
Submitted by:	Unit #:
Reference:	Drawing #:



### INDOOR SPECIFICATION

ESP(inWG)		0~0.8
Indoor Air Flow (Turbo/H/ML/SI) (CFM)		1601 / 1442 / 1265 / 1089 / 1089
Indoor Noise Level (Turbo/H/ML/SI) (dBA)		53 / 53 / 49.5 / 33.5 / 33.5
Dimension (WxDxH)	inch	21-1/2 x 21-1/2 x 60-1/8
	mm	546 x 546 x 1526
Package (WxDxH)	inch	25 x 31-1/8 x 70-3/4
	mm	635 x 790 x 1800
Net/Gross Weight	lbs	187 / 232
	kg	84.6 / 105.3

### OUTDOOR SPECIFICATION

Compressor Type		ROTARY
Compressor Model		MTH550UKPC8FU
Refrigerant		R454B
Refrigerant Oil Charge(mL)		1,800
Refrigerant Oil		HAF68D1C
Outdoor Air Flow (Max) (CFM)		3,037
Outdoor Noise Level (dBA)		65
Dimension (WxDxH)	inch	38-9/16 x 16-3/8 x 38-3/8
	mm	980 x 415 x 975
Package (WxDxH)	inch	45-1/16 x 19-11/16 x 42-1/2
	mm	1145 x 500 x 1080
Net/Gross Weight	lbs	233 / 202
	kg	105.5 / 91.4

### EFFICIENCY

Cooling		Heating	
SEER2	17.5	HSPF2-4	9.5
EER2	12.0	COP	3.28

### PERFORMANCE of Cooling

Cooling (Btu/hr)	
Rated Capacity	48,000
Min/Max Capacity	18,000 ~ 52,000
Moisture Removal(L/h)	4.94
Standard Operating Range(*F/*C)	-22~122(-30 ~ 50)
Rated Cooling Conditions:	Indoor: 80°F DB/67°F WB Outdoor: 95°F DB/75°F WB

### PERFORMANCE of Heating

Heating (Btu/hr)	
1. @ 47°F Rated	48,000
2. @ 47°F Min/Max Capacity	13,500 ~ 52,000
3. @ 17°F Rated	34,000
4. @ 5°F Rated: Capacity / COP	48,000 / 2
5. @ 5°F Max: Capacity	48,000
Standard Operating Range(*F/*C)	-22~75 (-30 ~ 24)
1. Rated Heating Conditions:	Indoor: 70°F DB/60°F WB Outdoor: 47°F DB/43°F WB
2. Rated Heating Conditions:	Indoor: 70°F DB/60°F WB Outdoor: 17°F DB/15°F WB
3. Heating Conditions, Compressor Operating at Max. Frequency	Indoor: 70°F DB/60°F WB Outdoor: 5°F DB/5°F WB

### ELECTRICAL

Indoor Power Supply	115/208/230V,60Hz,1Ph
Indoor MCA 115V/(208/230V)	14.5/10
Indoor MOP	15.0
Outdoor Power Supply	208/230V,60Hz,1Ph
Outdoor MCA	38.0
Outdoor MOP	40.0
Communication Wiring	AWG 20/2
Compressor RLA	28.0
Outdoor Fan Motor RLA	2.0
Outdoor Fan Motor W	250
Indoor Fan Motor RLA	8.0
Indoor Fan Motor W	1000
System Power Input @ Cooling (W)	4,000 (1,300 ~ 4,870)
System Power Input @ Heating (W)	4,290 (925 ~ 3,880)
MCA: Min. circuit amps (A)	MOCP: Max. over current protection (A)
RLA: Rated load amps (A)	W: Fan motor rated output (W)

### PIPING

Throttle type(Indoor)	EXV
Throttle type(Outdoor)	EXV
Liquid Size	3/8" (9.52mm)
Gas Size	3/4" (19mm)
Max. Piping Length(ft/m)	246 (75)
Max. Height Difference(ft/m)	98 (30)
Max. Pre-charged Length(ft/m)	25 (7.5)
Refrigerant Pre-charged Amount(oz/kg)*	134 (3.8)
Additional Charge of Refrigerant(oz/ft)/(g/m)	0.7 (65)
Connection Method	Flared

\* When MO1HE-H48B-2A is paired with MAUSE-H48B-2A, an additional 0.65kg/22.93oz of refrigerant is required.

Indoor Unit Dimension

Unit: inch, mm

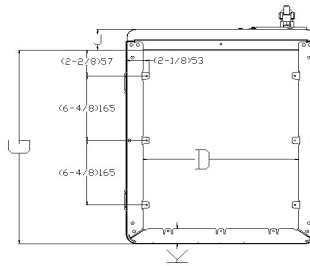
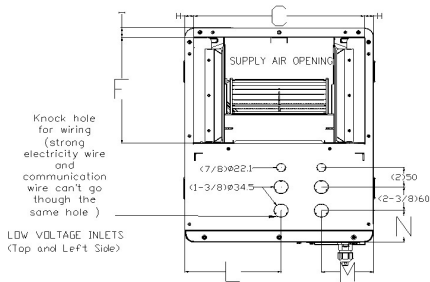
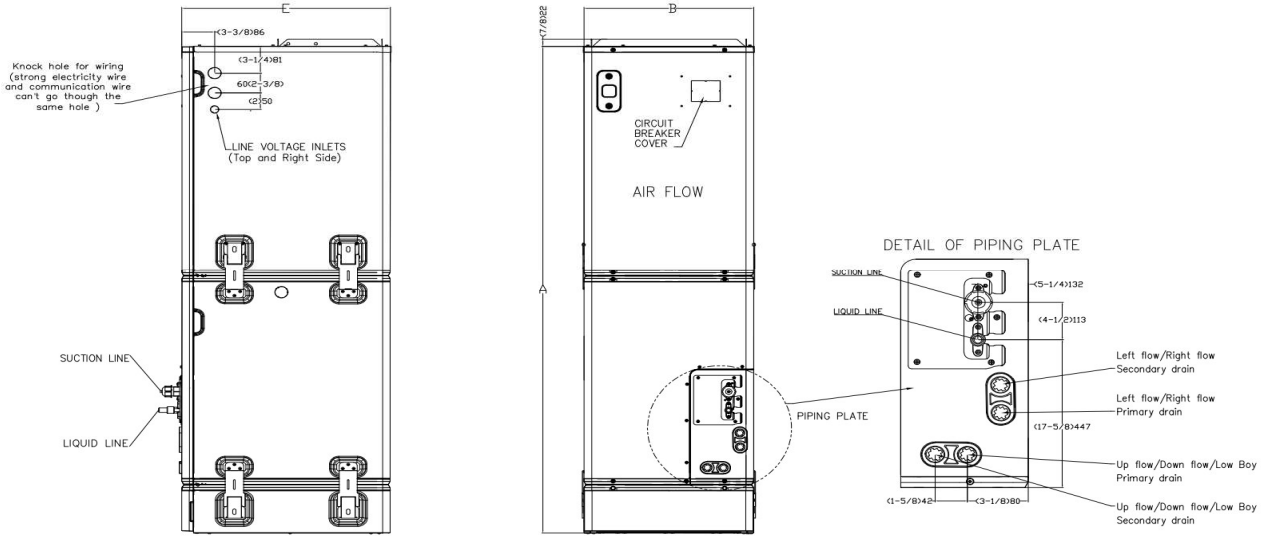

Dimensions		Model(Btu/h)		18K/24K		30K/36K		48K/54K	
		inch	mm	inch	mm	inch	mm		
A	Model Height	53-7/8	1368	58-1/8	1476	60-1/8	1526		
B	Model Width	14-4/8	368	17-4/8	445	21-4/8	546		
C	Supply Air Opening Width	12-7/8	328	16	405	19-7/8	506		
D	Return Air Opening Width	11-1/8	282	14-4/8	368	18-4/8	470		
E	Model Depth	21-1/2	546	21-1/2	546	21-1/2	546		
F	Supply Air Opening Depth	10-5/8	271	10-5/8	271	10-5/8	271		
G	Return Air Opening Depth	19	484	19	484	19	484		
H	Supply Air Opening Clearance	7/8	22	7/8	22	7/8	22		
I	Supply Air Opening Clearance	1	24	1	24	1	24		
J	Return Air Opening Front Clearance	2-4/8	62	2-4/8	62	2-4/8	62		
K	Return Air Opening Back Clearance	1-4/8	37	1-4/8	37	1-4/8	37		
L	Top cover knock hole	/	/	9	229	10-7/8	275		
M	Top cover knock hole	4-1/2	113	4-7/8	124	5-1/8	131		
N	Top cover knock hole	2	51	2	51	1-5/8	41		

Outdoor Unit Dimension

Unit: inch (mm)

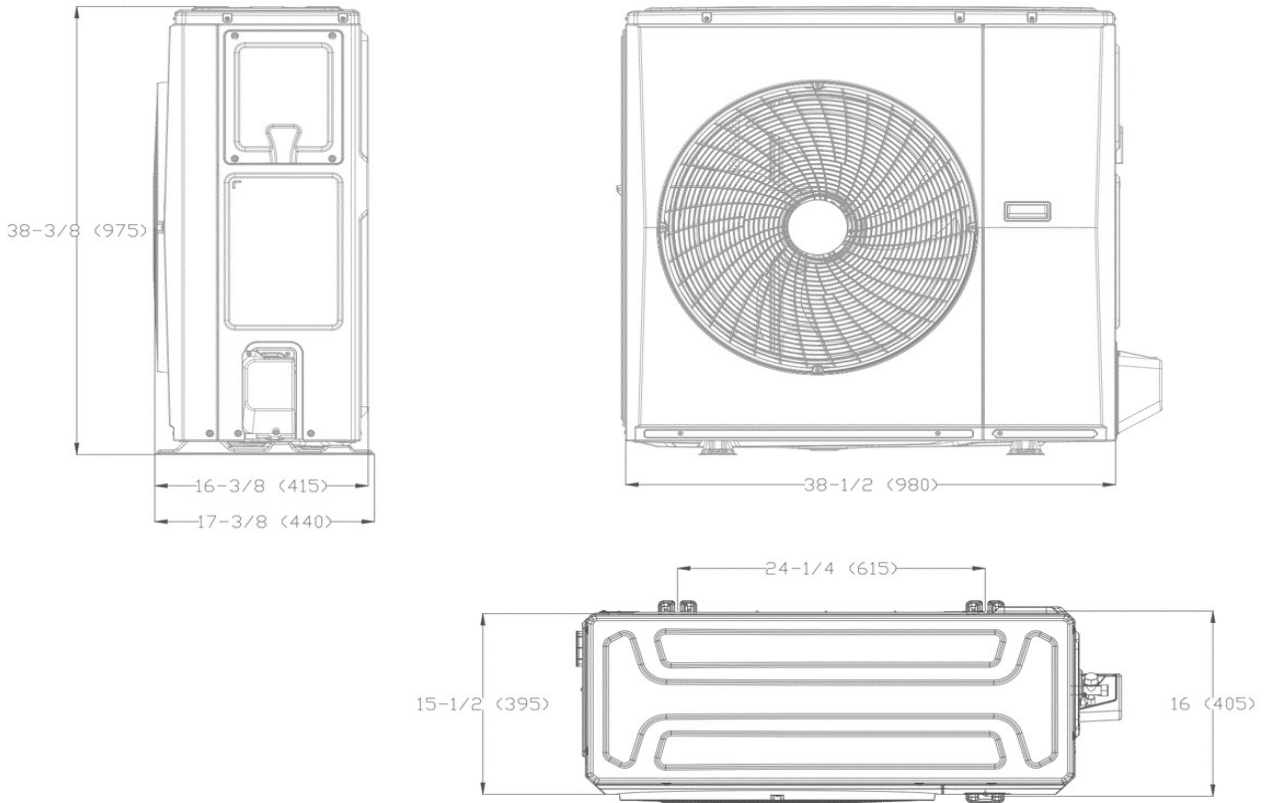

Installation Instruction For Outdoor Unit

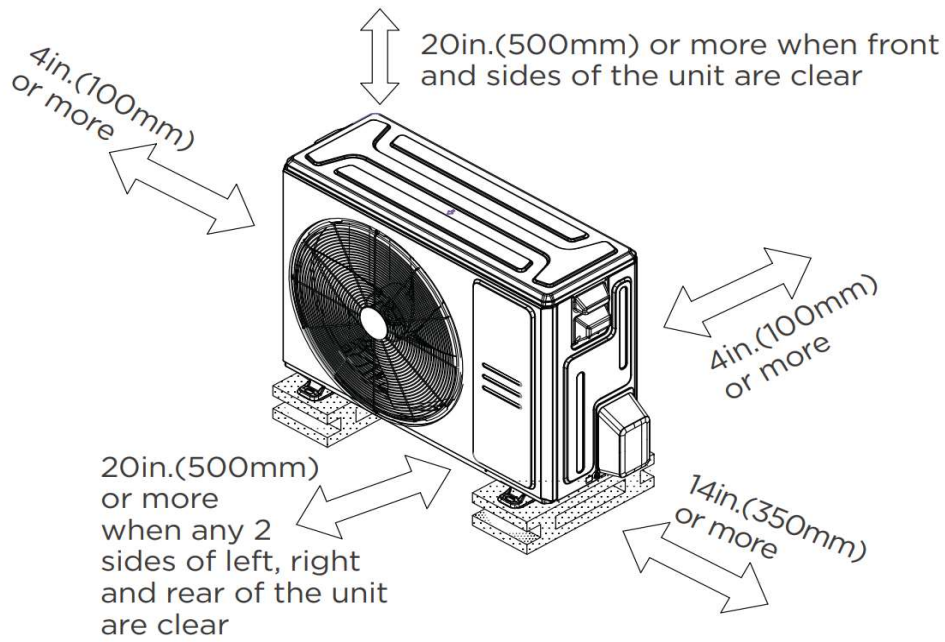

### Fan Performance For Indoor Unit

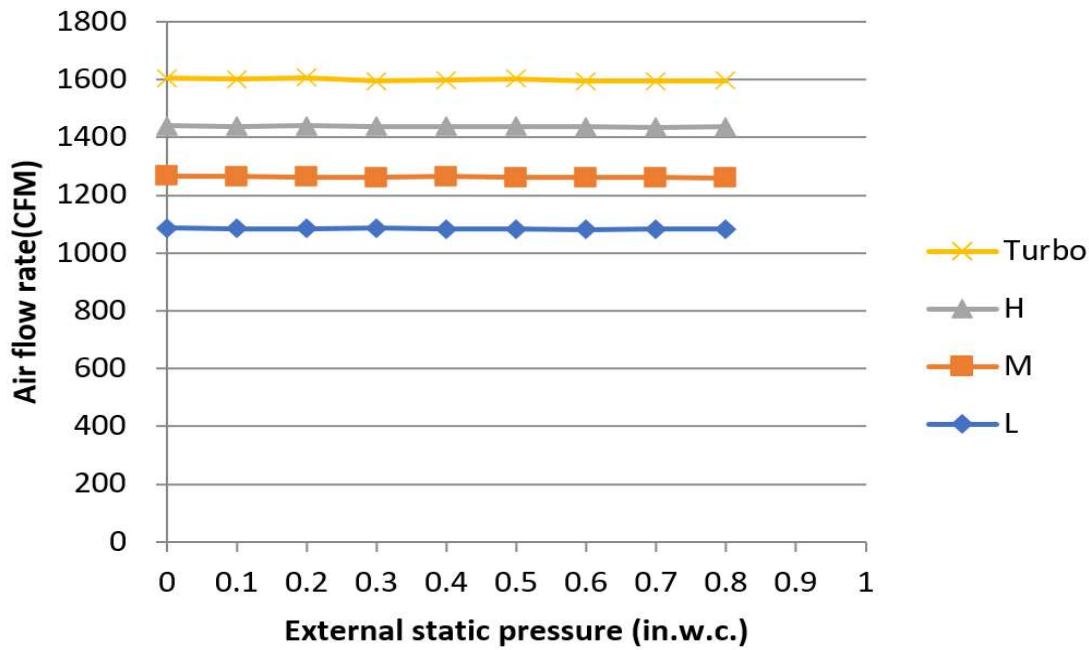

### Features

- Multi-position installation: horizontal(left or right), vertical( up or down)
- The IDU supports 115/230V voltage compatibility
- Aluminum Coil
- Constant Air Flow system: Up to 1.0 In.W.G
- Optional Auxiliary heat kit up to 25kW
- Easy Maintenance
- Multiple control options available:
  - Two-way communication wired controller:120N(X6)
  - Two-way communication wired controller with built-in Wi-Fi: 120N (X6W)
  - Wireless remote controller
  - Third-Party 24V Thermostat
- Adaptive Control System
- High efficiency up to 19 SEER2, 12.5 EER2, 10.8 HSPF2
- 100% heating output down to -13°F\*
- Base pan heater and crankcase heater are equipped as standard

\* When MAUSE-H36B-2A is paired with MO1SE-H36B-2A, its rated heating capacity at -13°F is 100%