



# User Manual

## Packaged Window Heat Pump

### Wireless Model



SmartHome

Download the app  
& activate product

Packaged Window Heat Pump Models

MAH09S1AGR

MAH09H1AGR

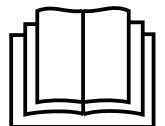
#### NOTE

Before using this product, please read this manual carefully and keep it for future reference.

The design and specifications are subject to change without prior notice for product improvement.

Please consult with your dealer or manufacturer for further details.

The diagram above is just for reference. Please consider the appearance of the actual product as the standard.



# Table of Contents

<b>Thank You</b> .....	<b>2</b>
<b>Safety Instructions</b> .....	<b>3</b>
Explanation of Symbols .....	3
<b>Product Installation</b> .....	<b>8</b>
Tools You Will Need .....	8
Installation Hardware .....	9
1 - Prepare the Window .....	10
2 - Install Main Bracket – Outdoor Component .....	10
3 - Install Main Bracket – Indoor Component .....	12
4 - Install Main Bracket – Final Steps .....	12
5 - Install the Unit .....	14
6 - Foam Installation .....	17
<b>Operation Instructions</b> .....	<b>19</b>
Normal Sounds .....	19
Sound Performance .....	19
Unit Operation .....	20
Air Directional Louvers .....	20
Unit Features .....	21
<b>Connection Instructions</b> .....	<b>22</b>
Declaration of Conformity .....	22
Specification of the Wireless Module .....	23
<b>Remote Control Operation</b> .....	<b>25</b>
Quick Start Guide .....	25
Handling the Remote Control .....	25
Buttons And Functions .....	27
Remote Screen Indicators .....	28
How To Use Basic Functions .....	29
How To Use Advanced Functions .....	32
<b>Cleaning And Maintenance</b> .....	<b>33</b>
Air Filter Cleaning .....	33
Cabinet Cleaning .....	33
Pump Filter Cleaning .....	34
<b>Troubleshooting</b> .....	<b>35</b>
<b>Error Codes</b> .....	<b>37</b>
Trademarks Copyrights & Legal Statement .....	37
Data Protection Notice .....	37

## Thank You

Thank you for choosing Midea! Before using your new Midea product, please read this manual thoroughly to ensure that you know how to operate the features and functions that your new unit offers in a safe way.

## Read this manual

Inside you'll find many helpful hints on how to use and maintain your unit properly. Just a little preventive care on your part can save you a great deal of time and money over the life of your unit.

You'll find many answers to common problems in the troubleshooting tips - you should be able to fix most of them quickly before calling service. These instructions may not cover every possible condition of use, so common sense and attention to safety is required when installing, operating and maintaining this product.

Make sure to save this manual for possible future use in removing or installing this unit. If you have any additional questions or need support, please call the Service Center at 1-866-646-4332.

**IMPORTANT NOTE:** Read this manual carefully before installing or operating your new air conditioning unit. Make sure to save this manual for future reference.



## Caution:

Risk of fire/flammable materials  
(Required for R32 units only)



# A2L

# Safety Instructions

## Explanation of Symbols

Please read the Safety Precautions before operation and installation. To prevent injury to the user or other people and property damage, the instructions shown here must be followed. Incorrect operation or installation due to ignoring instructions may cause harm or damage. The level of risk is shown by the following indications, which will be used throughout this user manual.

### **WARNING**

The signal word indicates a hazard with a medium level of risk, which, if not avoided, may result in death or serious injury.






### **CAUTION**

The signal word indicates a hazard with a low degree of risk, which, if not avoided, may result in minor or moderate injury.

### **NOTE**

This signal word indicates important information (e.g., property damage), but not danger.

### Explanation of symbols

<p><b>A2L</b></p>  	<p><b>WARNING</b></p>	<p>This symbol shows that this appliance uses a flammable refrigerant. If the refrigerant is leaked and exposed to an external ignition source, there is a risk of fire.</p>
	<p><b>CAUTION</b></p>	<p>This symbol shows that the operation manual should be read carefully.</p>
	<p><b>CAUTION</b></p>	<p>This symbol shows that service personnel should handle this equipment with reference to the installation manual.</p>
	<p><b>CAUTION</b></p>	<p>This symbol shows that information is available, such as the operating manual or installation manual.</p>

### **WARNING**

State of California Proposition 65 Warning (US Only)

This product contains chemicals known to the State of California to cause cancer, birth defects, or other reproductive harm.

### **WARNING**

#### **POWER CORD**

The following instructions regarding the power cord and connecting the unit to power must be followed to reduce

#### Packaged Window Heat Pump

the risk of fire and electric shock, which could cause serious injury or death.

- Plug in power cord plug properly.
- Install the appliance into a dedicated, 15-amp outlet. Do not share the appliance's outlet with other electrical appliances.
- The power cord is equipped with a three-prong grounding plug for protection against shock hazards. Do not cut or remove any prongs from the power cord.
- Your unit must be used in a properly grounded 3-prong wall outlet. If the wall outlet you intend to use is not a 3-prong outlet and is protected by a time delay fuse or circuit breaker, have a qualified electrician install the proper receptacle.
- Be sure the unit is plugged into an electrical outlet that has a voltage rating adequate for the model you have chosen. The voltage rating can be found on the serial plate of the unit, located on the side panel.
- Do not plug the unit into a wall socket that is loose or damaged.
- Hold the plug by the head of the power plug when taking it out to avoid an electric shock. Do not pull by the cord or touch the prongs.
- Do not damage or use an alternate power cord.
- Do not use an adapter plug or extension cord with this appliance.
- Ensure the receptacle is accessible after the unit installation.
- Do not place heavy objects such as furniture on the power cord, and take care that the cord is never pinched.
- Power voltage should be within 90-110% of rated voltage. An insufficient power supply can cause malfunction, electrical shock, or fire.



### **WARNING**

#### **FLAMMABLE REFRIGERANT**

Flammable refrigerant R32 is used within the unit. Please follow the instructions below carefully on how to handle, install, and store the unit to avoid hazards due to the refrigerant.



- Please check with your local disposal company on what to do.
- If the power cord is damaged, it must be replaced by the manufacturer or an authorized service center, or a similarly qualified person.

#### **OPERATION AND USE**

The following instructions regarding operation and use must be followed to reduce the risk of fire, electric shock, or personal injury.

- Do not operate your unit in a humid room such as a bathroom or laundry room.
- Do not store or operate the unit close to heating appliances. It may cause fire or electric shock.
- Unplug the unit if you notice unusual sounds, smells, or smoke coming from it.
- Do not allow water to come into contact with any electric parts.
- Do not disassemble or modify the unit.

- Do not open any compartments on the unit during operation, such as air filter covers.
- Do not hang on the unit.
- Do not drink the drain water.
- Do not use in places where water may splash onto the unit.
- This appliance is not intended for use by people (including children) with reduced physical, sensory, or mental capabilities or lack of experience and knowledge, unless they have been given supervision or instruction concerning use of the appliance by a person responsible for their safety.
- Children should be supervised to ensure that they do not play with the appliance.

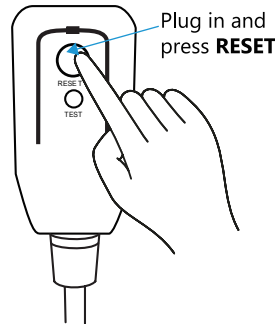
### ⚠ CAUTION

- The appliance shall be installed in accordance with national wiring regulations.
- Do not obstruct the air inlets or air outlets of the unit. This may cause a decrease in performance or failure.
- Always use two people when lifting the unit and use proper lifting techniques when installing.
- Do not use this unit to preserve precision devices, food, pets, plants, and art objects.

#### Operation of Current Device

The power supply cord contains a current device that senses damage to the power cord. To test your power supply cord, do the following:

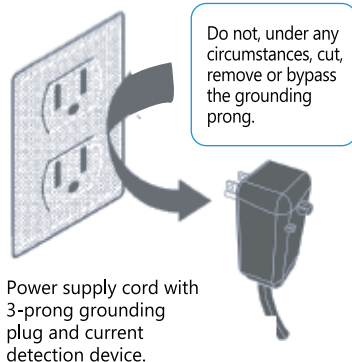
1. Plug in the Unit.
2. The power supply cord will have TWO buttons on the plug head. Press the **TEST** button, you will notice a click as the **RESET** button pops out.
3. Press the **RESET** Button again, you will notice a click as the button engages.
4. The power supply cord is now supplying electricity to the unit. (On some products, this is also indicated by a light on the plug head.)



### ⚠ WARNING

#### GROUNDING-TYPE WALL RECEPTACLE

- The power supply cord with this unit contains a current detection device designed to reduce the risk of fire.
- If the power supply cord is damaged, it cannot be repaired - it must be replaced with a cord from the product manufacturer.
- Do not insert or pull out the power cord plug to turn the unit on or off
- Always make sure the **RESET** button is pushed in for correct operation.



- The power supply cord must be replaced if it fails to reset when either the **TEST** button is pushed or if it cannot be reset. Please contact Customer Service.

### ⚠ WARNING

- Servicing shall only be performed as recommended by the equipment manufacturer. Maintenance and repair requiring the assistance of other skilled personnel shall be carried out under the supervision of the person competent in the use of flammable refrigerants.
- **DO NOT** modify the length of the power cord or use an extension cord to power the unit.
- **DO NOT** share a single outlet with other electrical appliances. Improper power supply can cause fire or electrical shock.
- Please follow the instructions carefully to handle, install, clear, and service the appliance to avoid any damage or hazard.
- Flammable Refrigerant R32 is used within the appliance.
- When maintaining or disposing of the appliance, the refrigerant (R32) shall be recovered properly, and shall not be discharged into the air directly.
- Compliance with national gas regulations shall be observed.
- Keep ventilation openings clear of obstruction.
- The appliance shall be stored to prevent mechanical damage from occurring.
- The appliance shall be stored in a well-ventilated area where the room size corresponds to the room area as specified for operation.
- Any person who is involved with working on or breaking into a refrigerant circuit should hold a current valid certificate from an industry-accredited assessment authority, which authorizes their competence to handle refrigerants safely in accordance with an industry-recognized assessment specification. All training shall follow the ANNEX HH requirements of UL 60335-2-40 4th Edition. Examples for such working procedures are:
  - Breaking into the refrigerating circuit;
  - Opening of sealed components;
  - Opening of ventilated enclosures.
- No open fire or device like a switch that may generate sparks/arcing shall be around the appliance to avoid causing ignition of the flammable refrigerant used.

Please follow the instructions carefully when storing or maintaining the appliance to prevent mechanical damage from occurring.

- Do not use means to accelerate the defrosting process or to clean, other than those recommended by the manufacturer.
  - The appliance shall be stored in a room without continuously operating ignition sources (for example: open flames, an operating gas appliance) and ignition sources (for example: an operating electric heater) close to the appliance.
  - Do not pierce or burn.
    - Be aware that the refrigerants may not contain an odor.
1. Transport of equipment containing flammable refrigerants
    - See transport regulations.

2. Marking of equipment using signs
  - See local regulations.
3. Disposal of equipment using flammable refrigerants
  - See national regulations.
4. Storage of equipment/appliances
  - The storage of the appliance should be in accordance with the applicable regulations or instructions, whichever is more stringent.
5. Storage of packed (unsold) equipment
  - Storage package protection should be constructed such that mechanical damage to the equipment inside the package will not cause a leak of the refrigerant charge.
  - The maximum number of pieces of equipment permitted to be stored together will be determined by local regulations.
6. Information on servicing
  1. Checks in the area- Before beginning work on systems containing flammable refrigerants, safety checks are necessary to ensure that the risk of ignition is minimized. For repairing the refrigerating system, the following precautions shall be complied with before conducting work on the system.
  2. Work procedure- Work shall be undertaken under a controlled procedure to minimize the risk of a flammable gas or vapor being present while the work is being performed.
  3. General work area- All maintenance staff and others working in the local area shall be instructed on the nature of work being carried out. Work in confined spaces shall be avoided. The area around the workspace shall be sectioned off. Ensure that the conditions within the area have been made safe by control of flammable material.
  4. Checking for presence of refrigerant- The area shall be checked with an appropriate refrigerating detector before and during work, to ensure the technician is aware of potentially flammable atmospheres. Ensure that the leak detection equipment being used is suitable for use with flammable refrigerants, i.e. non-sparking, adequately sealed, or intrinsically safe.
  5. Presence of fire extinguisher- If any hot work is to be conducted on the refrigeration equipment or any associated parts, appropriate fire extinguishing equipment shall be available to hand. Have a dry powder or CO<sub>2</sub> fire extinguisher adjacent to the charging area.
  6. No ignition sources- No person carrying out work in relation to a refrigerating system which involves exposing any pipe work that contains or has contained flammable refrigerant shall use any sources of ignition in such a manner that it may lead to the risk of fire or explosion. All possible ignition sources, including cigarette smoking, should be kept sufficiently far away from the site of installation, repairing, removing, and disposal, during which flammable refrigerant can possibly be released to the surrounding space. Before work takes place, the area around the equipment is to be surveyed to make sure that there are no flammable hazards or ignition risks. No Smoking signs shall be displayed.
  7. Ventilated area- Ensure that the area is in the open or

that it is adequately ventilated before breaking into the system or conducting any hot work. A degree of ventilation shall continue during the period that the work is carried out. The ventilation should safely disperse any released refrigerant and preferably expel it externally into the atmosphere.

8. Checks of the refrigerating equipment- Where electrical components are being changed, they shall be fit for the purpose and to the correct specifications. At all times, the manufacturer's maintenance and service guidelines shall be followed. If in doubt, consult the manufacturer's technical department for assistance. The following checks shall be applied to installations using flammable refrigerants: the actual refrigerant charge is in accordance with the room size within which the refrigerant containing parts are installed; the ventilation machinery and outlets are operating adequately and are not obstructed; if an indirect refrigerating circuit is being used, the secondary circuit shall be checked for the presence of refrigerant; marking to the equipment continues to be visible and legible. markings and signs that are illegible shall be corrected, and refrigerating pipes or components shall be installed in a position where they are unlikely to be exposed to any substance which may corrode refrigerant-containing components, unless the components are constructed of materials which are inherently resistant to being corroded or are suitably protected against being so corroded.
9. Checks of electrical devices- Repair and maintenance to electrical components shall include initial safety checks and component inspection procedures. If a fault exists that could compromise safety, then no electrical supply shall be connected to the circuit until it is satisfactorily dealt with. If the fault cannot be corrected immediately, but it is necessary to continue operation, an adequate temporary solution shall be used.
  - This should be reported to the owner of the equipment, so all parties are advised.
  - Initial safety checks shall include:
    - The capacitors are discharged: this shall be done safely to avoid the possibility of sparking; that there are no live electrical components and wiring exposed while charging, recovering, or purging the system; that there is continuity of earth bonding.
7. Sealed electrical components shall be replaced.
8. Intrinsically safe components must be replaced.
9. Wiring
  - Check that cabling will not be subject to wear, corrosion, excessive pressure, vibration, sharp edges, or any other adverse environmental effects. The check shall also consider the effects of aging or continual vibration from sources such as compressors or fans.
10. Detection of flammable refrigerants
  - Under no circumstances shall potential sources of ignition be used in the search for or detection of refrigerant leaks. A halide torch (or any other detector using a naked flame) shall not be used.
  - The following leak detection methods are deemed acceptable for systems containing flammable refrigerants. Electronic leak detectors should be used to

detect flammable refrigerants, but the sensitivity may not be adequate or may need recalibration. (Detection equipment shall be calibrated in a refrigerant-free area.) Ensure that the detector is not a potential source of ignition and is suitable for the refrigerant used.

Leak detection equipment shall be set at a percentage of the LFL of the refrigerant and shall be calibrated to the refrigerant employed, and the appropriate percentage of gas (25% maximum) is confirmed. Leak detection fluids are suitable for use with most refrigerants, but the use of detergents containing chlorine shall be avoided as the chlorine may react with the refrigerant and corrode the copper pipework. If a leak is suspected, all naked flames shall be removed/extinguished. If a leakage of refrigerant is found that requires brazing, all of the refrigerant shall be recovered from the system or isolated (utilizing shut-off valves) in a part of the system remote from the leak. Removal of refrigerant shall be according to the Removal and evacuation.

#### 11. Removal and evacuation

When breaking into the refrigerant circuit to make repairs—or for any other purpose - conventional procedures shall be used. However, for flammable refrigerants, best practice must be followed, since flammability is a consideration. The following procedure shall be adhered to:

- Safely remove refrigerant following local and national regulations;
- Evacuate;
- Purge the circuit with inert gas (optional for A2L).
- Evacuate (optional for A2L).
- Continuously flush or purge with inert gas when using flame to open circuit; and
- Open the circuit.

The refrigerant charge shall be recovered into the correct recovery cylinders if venting is not allowed by local and national codes. For appliances containing flammable refrigerants, the system shall be purged with oxygen-free nitrogen to render the appliance safe for flammable refrigerants. This process might need to be repeated several times. Compressed air or oxygen shall not be used for purging refrigerant systems. For appliances containing flammable refrigerants, refrigerant purging shall be achieved by breaking the vacuum in the system with oxygen-free nitrogen and continuing to fill until the working pressure is achieved, then venting to atmosphere, and finally pulling down to a vacuum (optional for A2L).

This process shall be repeated until no refrigerant is within the system (optional for A2L). When the final oxygen-free nitrogen charge is used. The system shall be vented down to atmospheric pressure to enable work to take place. The outlet for the vacuum pump shall not be close to any potential ignition sources, and ventilation shall be available.

#### 12. Charging procedures

In addition to conventional charging procedures, the following requirements shall be followed. Ensure that contamination of different refrigerants does not occur when using charging equipment. Hoses or lines shall be as short as possible to minimize the amount of refrigerant

contained in them. Cylinders should be kept in an appropriate position according to the instructions. Ensure that the refrigeration system is earthed before charging the system with refrigerant. Label the system when charging is complete (if not already). Extreme care shall be taken not to overfill the refrigeration system. Before recharging the system, it shall be pressure tested with OFN. The system shall be leak tested on completion of charging but before commissioning. A follow-up leak test shall be carried out before leaving the site.

#### 13. Decommissioning

Before carrying out this procedure, the technician must be completely familiar with the equipment and all its details. It is recommended good practice that all refrigerants be recovered safely. Before the task is carried out, an oil and refrigerant sample shall be taken in case analysis is required before re-use of reclaimed refrigerant. Electrical power must be available before the task commences.

- a. Become familiar with the equipment and its operation.
- b. Isolate the system electrically.
- c. Before attempting the procedure, ensure that: mechanical handling equipment is available, if required, for handling refrigerant cylinders, all personal protective equipment is available and being used correctly; the recovery process is supervised at all times by a competent person; recovery equipment and cylinders conform to the appropriate standards.
- d. Pump down the refrigerant system, if possible.
- e. If a vacuum is not possible, make a manifold so that refrigerant can be removed from various parts of the system.
- f. Make sure that the cylinder is situated on the scales before recovery takes place.
- g. Start the recovery machine and operate in accordance with instructions.
- h. Do not overfill cylinders. (No more than 80% volume liquid charge.)
- i. Do not exceed the maximum working pressure of the cylinder, even temporarily.
- j. When the cylinders have been filled correctly and the process completed, make sure that the cylinders and the equipment are removed from the site promptly and all isolation valves on the equipment are closed off.
- k. Recovered refrigerant shall not be charged into another refrigeration system unless it has been cleaned and checked.

#### 14. Labelling

Equipment shall be labelled stating that it has been decommissioned and emptied of refrigerant. The label shall be dated and signed. Ensure that there are labels on the equipment stating that the equipment contains flammable refrigerant.

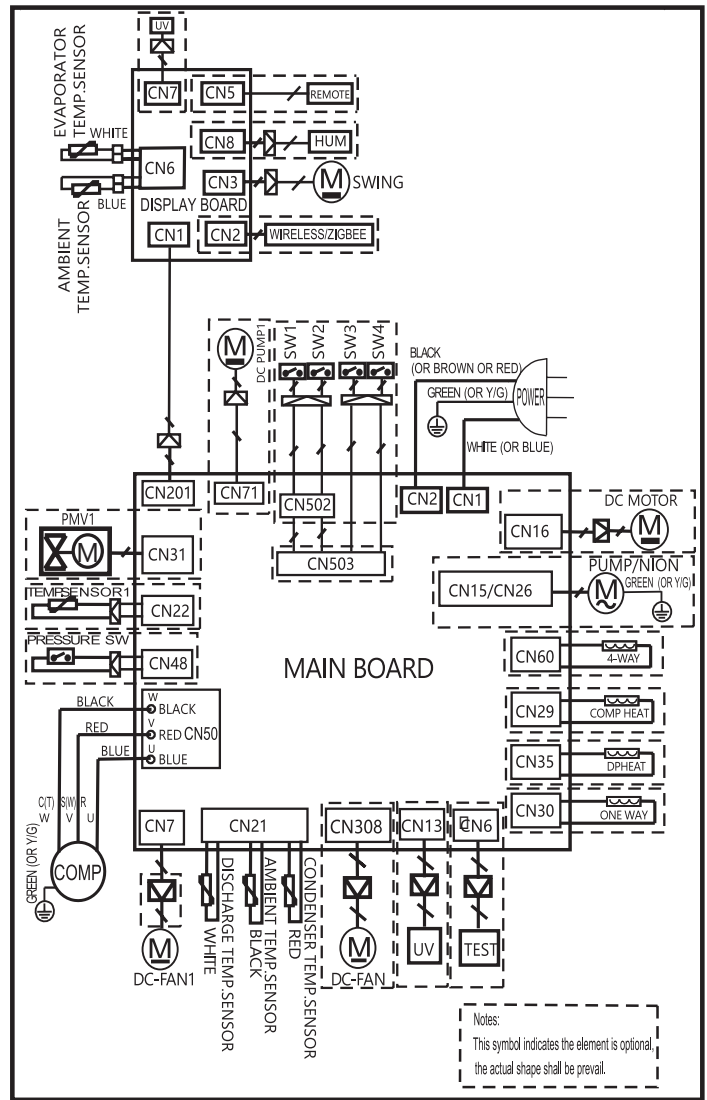
#### 15. Recovery

- When removing refrigerant from a system, either for servicing or decommissioning, it is recommended good practice that all refrigerants be removed safely. When transferring refrigerant into cylinders, ensure that only appropriate refrigerant recovery cylinders are employed. Ensure that the correct number of cylinders for holding the total system charge is available. All

cylinders to be used are designated for the recovered refrigerant and labelled for that refrigerant (i.e., special cylinders for the recovery of refrigerant). Cylinders shall be complete with pressure-relief valve and associated shut-off valves in good working order. Empty recovery cylinders are evacuated and, if possible, cooled before recovery occurs. The recovery equipment shall be in good working order, with a set of instructions concerning the equipment that is at hand and shall be suitable for the recovery of the flammable refrigerant.

- If in doubt, the manufacturer should be consulted. In addition, a set of calibrated weighing scales shall be available and in good working order. Hoses shall be complete with leak-free disconnect couplings and in good condition. The recovered refrigerant shall be processed according to local legislation in the correct recovery cylinder, and the relevant waste transfer note arranged. Do not mix refrigerants in recovery units and especially not in cylinders. If compressors or compressor oils are to be removed, ensure that they have been evacuated to an acceptable level to make certain that flammable refrigerant does not remain within the lubricant. The compressor body shall not be heated by an open flame or other ignition sources to accelerate this process. When oil is drained from a system, it shall be carried out safely.

## Electronic Type



### ELECTRONIC WORK

**⚠ WARNING**

BEFORE PERFORMING ANY ELECTRICAL OR WIRING WORK, TURN OFF THE MAIN POWER TO THE SYSTEM.

### NOTE

Please strictly follow the wiring label attached to the machine for all wiring connections. The wiring diagram may vary for different units. Please refer to the wiring diagram on the machine you have purchased. The above wiring diagram is a simplified representation for illustrative purposes only.

# Product Installation

## ⚠️ WARNING

### Before You Begin

Read these instructions completely and carefully.

- **IMPORTANT** - Save these instructions.
- **IMPORTANT** - Observe all governing codes and ordinances.

Before installation, please inspect the entire unit and the packaging appearance. If any oil leakage traces are found, please contact a qualified supplier for inspection.

Installation of this product requires the use of two people to properly place the unit into the installation space. Proper installation is the responsibility of the installer.

Product failure due to improper installation is not covered under the Limited Warranty.

You **MUST** use all supplied parts and use proper installation procedures as described in these instructions when installing this unit.

Do not, under any circumstances, cut or remove the third (ground) prong from the power cord. Do not change the plug on the power cord of the unit.

Aluminum house wiring may present special problems - consult a qualified electrician.

When handling the unit, be careful to avoid cuts from sharp metal edges and aluminum fins on front and rear coils. Please wear cut-resistant gloves.

The bracket should only be used for its intended purpose. If not, the warranty will be voided.

This unit releases a mist rather than collecting condensation. Ensure it is installed away from walkways or areas with high foot traffic to prevent slip hazards.

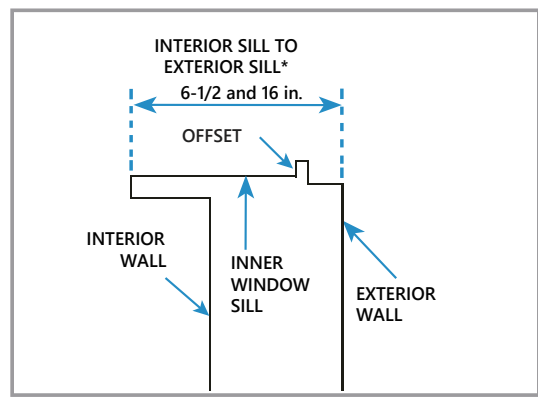
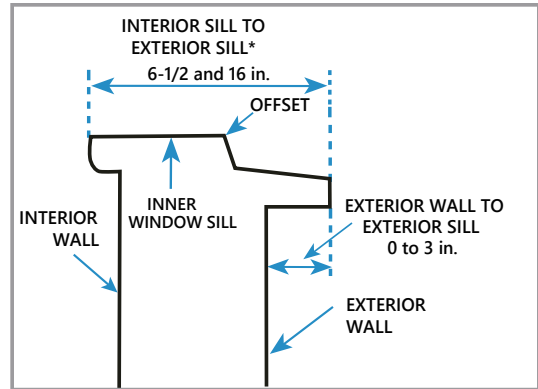
### Window Requirements

Your unit is designed to install in standard double-hung

windows with opening widths at least 26 in. and a window opening height of 15 in..

### NOTE

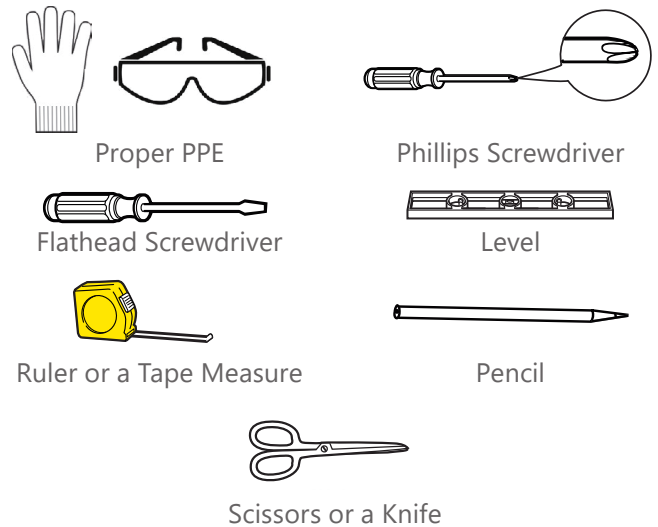
To ensure enough clearance below the window for the unit, do not install it in a window above a radiator.



### NOTE

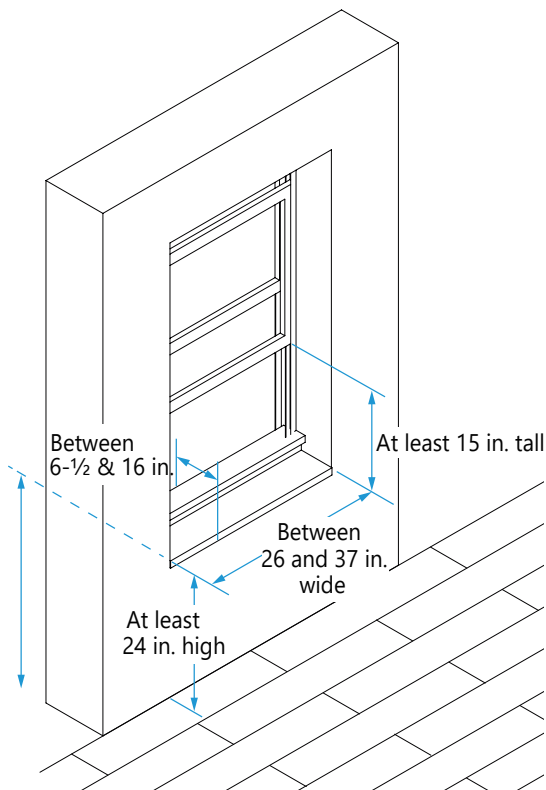
If the window does not have an interior or exterior sill, measure to the interior and exterior walls.

### Tools You Will Need

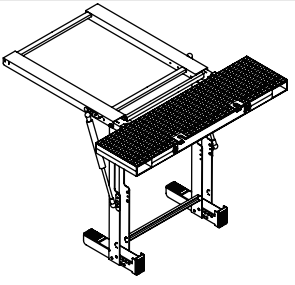
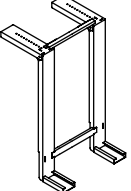


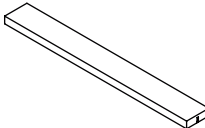
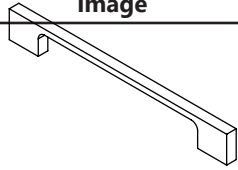





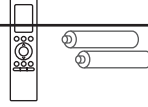


### NOTE

Only install this unit with the help of a second person to ensure it is done safely and correctly. Do not perform the installation alone.



## Installation Hardware

Quantity	Description	Image
1	Main Bracket - Outdoor Component	
1	Main Bracket - Indoor Component	
2	Window Sash Lock	
4	Adhesive Foam	
1	Windowsill Sealing Foam Strip	
Quantity	Description	Image
1	Top Sealing Foam Strip	
2	Cotter Pin	
2	Tapered Pin	
15	Screw	
2	Rubber Pad (extra only)	
3	Plastic Window Lock	
1	Remote Control and Batteries	

### NOTE

Save these Installation Instructions for future reference. If any piece of hardware is missing, **DO NOT INSTALL THE PRODUCT**, and call customer service at 1-866-646-4332.

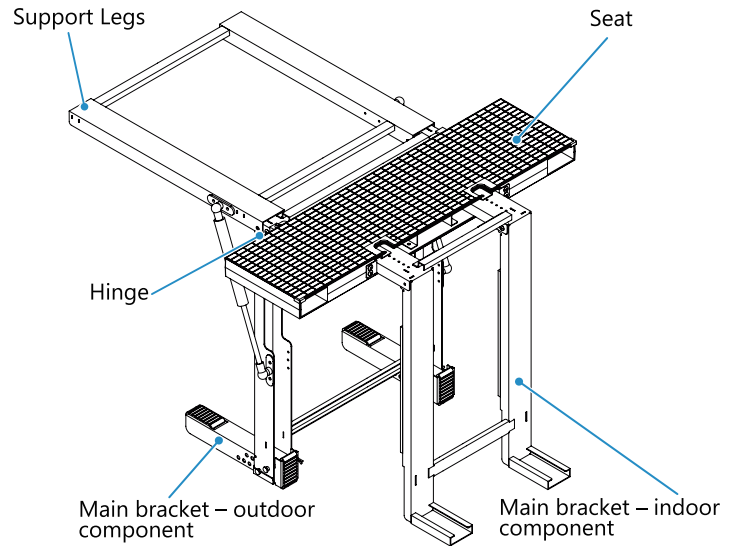


Fig. 1

### Before You Start

Unpack all the items in the box and ensure you have all the necessary components. The components of the bracket should be secured together with tape and plastic cable ties (zip ties).

Cut the tape shown in blue in the image below. This will disconnect the indoor component of the bracket from the rest of the bracket and free the support legs on the bottom. **KEEP** the zip ties on your actual bracket, shown on the right in red. Keep these zip ties in place until later in the installation process. This will keep the support legs from moving to make for an easier installation process.

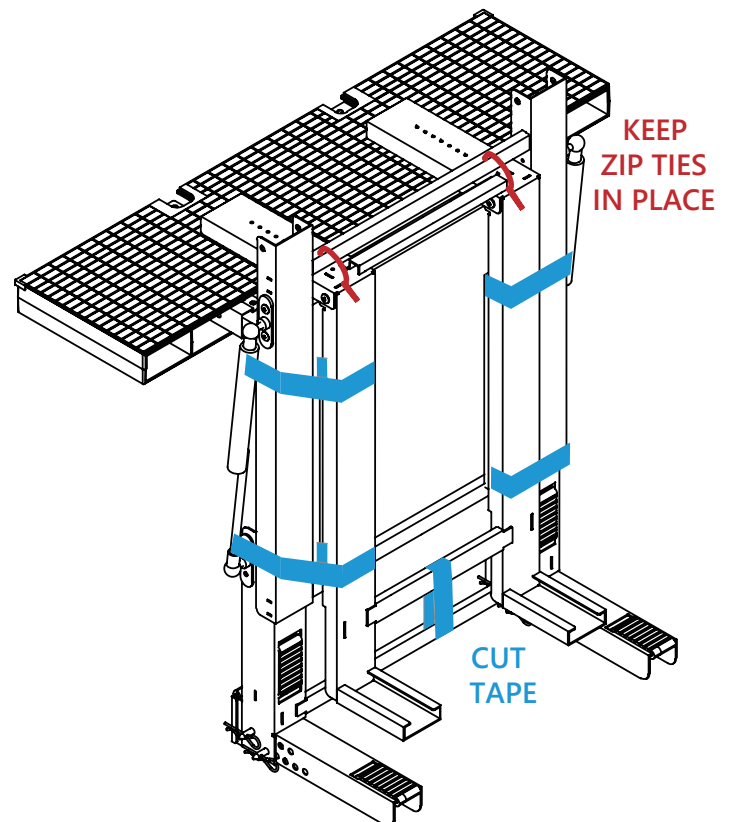


Fig. 2

# 1 - Prepare the Window

Place the window sealing foam strip in the windowsill, placing the side with the slit face down, thicker side towards the outdoors. If your window has a vinyl or aluminum lip, place the sealing foam strip so that the lip on the window sits within the slit on the foam. If your window does not have a lip, place the sealing foam strip in line with the window track.

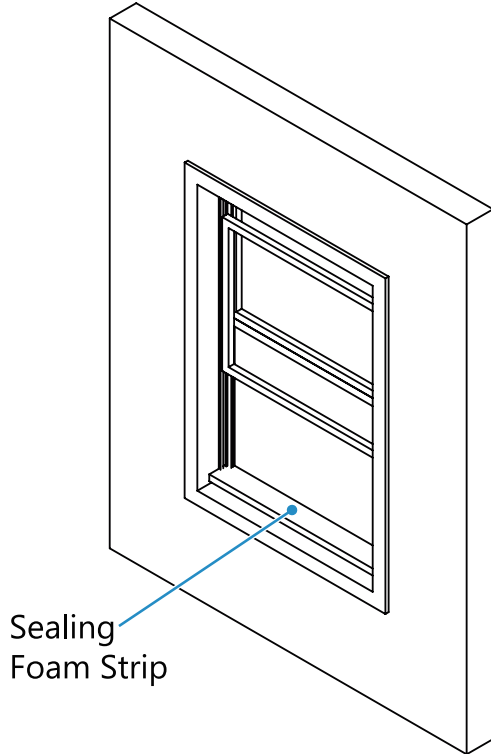


Fig. 3

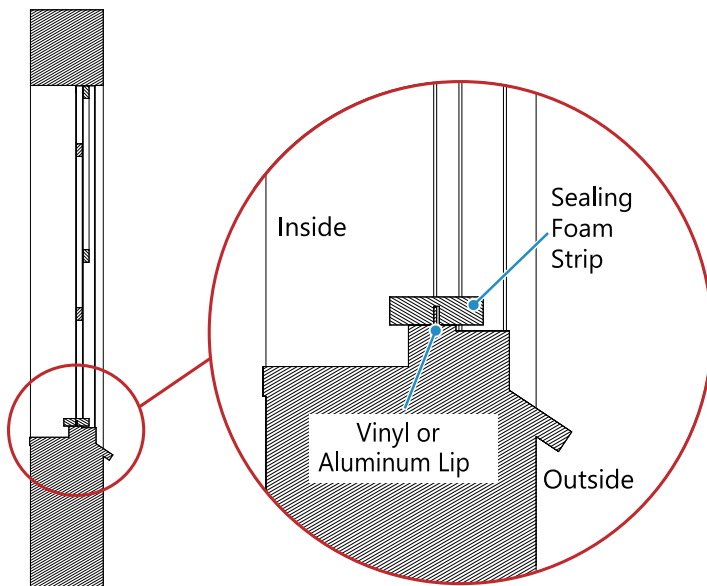


Fig. 4

# 2 - Install Main Bracket – Outdoor Component

A. Measure the distance between the outside wall (or edge of the outside windowsill if your window has one) to the center of the sealing foam strip. Record this measurement for the next step.

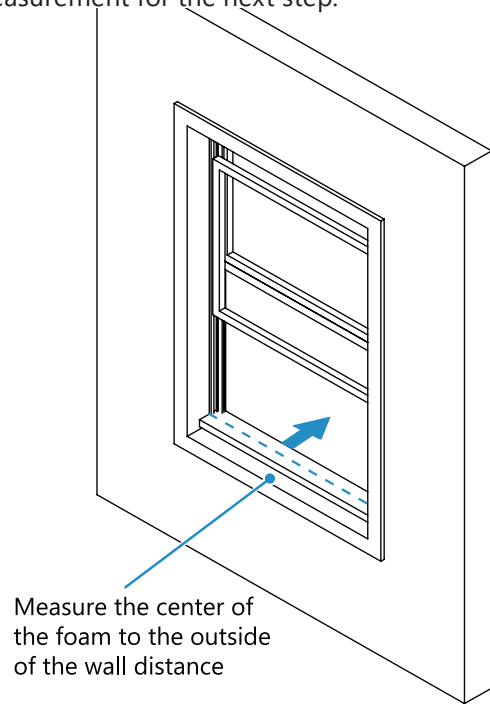


Fig. 5

B. Remove the 2 screws holding the seat to the outdoor legs. Adjust the outdoor legs so that the distance between the center of the seat and the outdoor legs is roughly the distance measured in step A. This will ensure the seat is centered over the sealing foam strip. Replace and tighten the screws.

Fig. 6

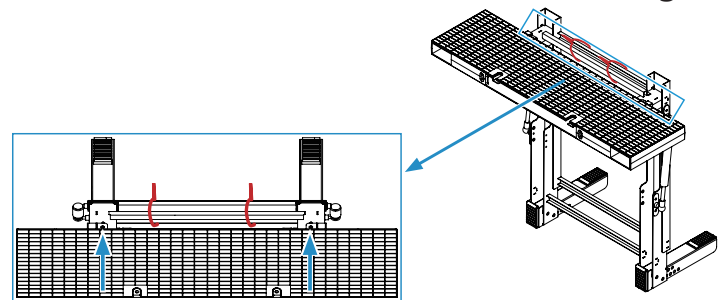
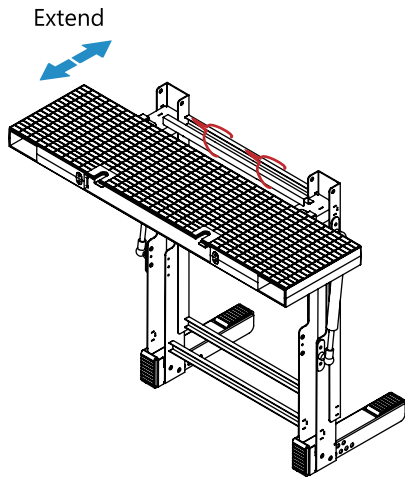
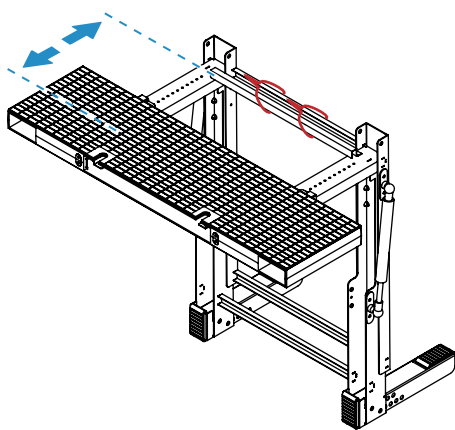


Fig. 6a



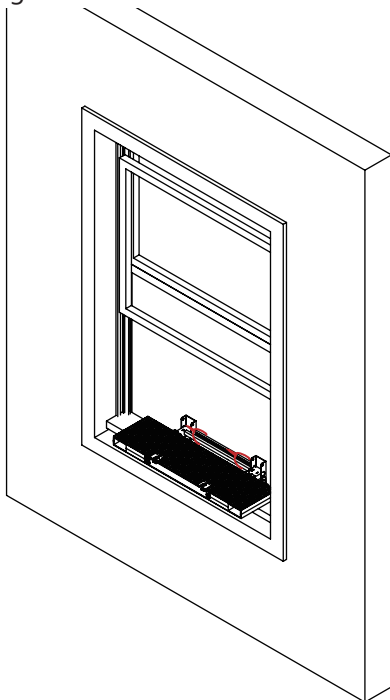
**Fig. 6b**

Adjust to match the distance measured in Step A



**Fig. 6c**

C. Place the outdoor half of the bracket in the window. Check that the seat is sitting over the foam strip as the outdoor legs contact the outdoor wall or the outdoor window ledge.

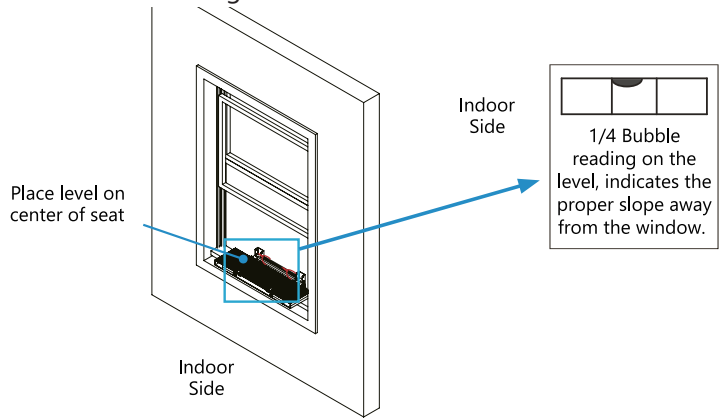


**Fig. 7**

Packaged Window Heat Pump

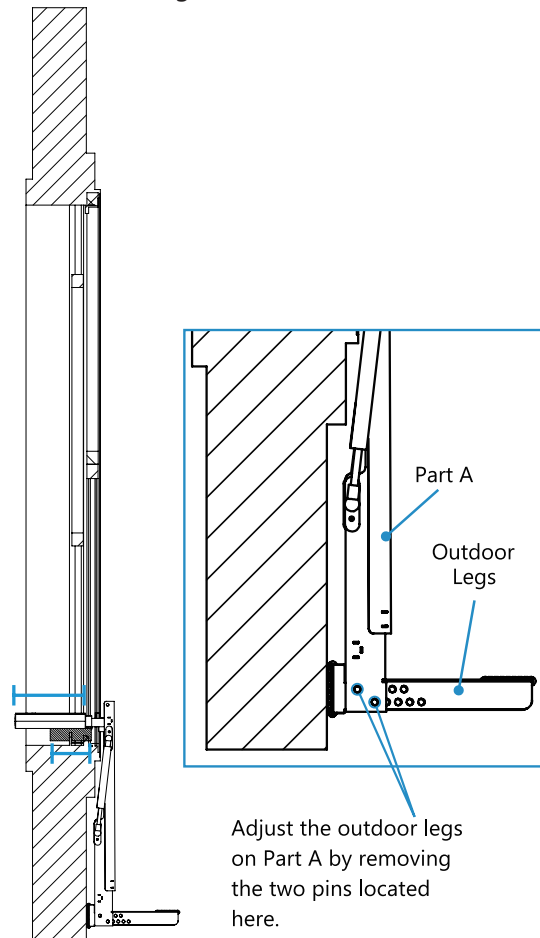
**⚠ WARNING**

Maintain control of the bracket until installation is complete.  
 D. Place the level onto the center of the seat of the bracket. The seat should be adjusted so it is sloped AWAY from the window, approximately 1/4 bubble on the level. Refer to the Figures below.



**Fig. 8**

E. Place the level onto the center of the seat of the bracket. The seat should be adjusted so it is sloped AWAY from the window, approximately 1/4 bubble on the level. Refer to the Figures below.



**Fig. 9**

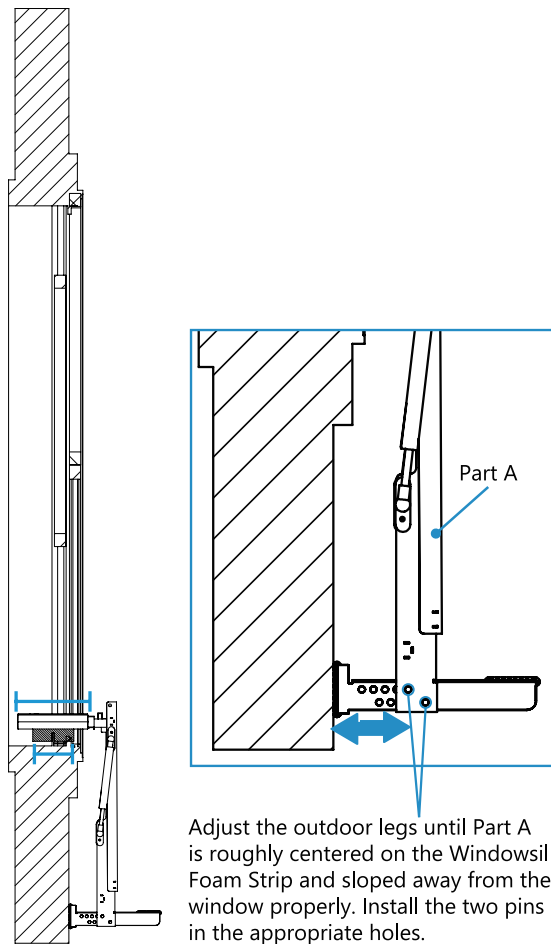


Fig. 10

### 3 - Install Main Bracket – Indoor Component

Keeping a hand on the outdoor component of the bracket, place the indoor component legs into the slots on the seat. **MAKE SURE YOU HAVE A FIRM GRIP ON THE OUTDOOR LEGS BEFORE PUSHING ON THE INDOOR LEGS TO SLIDE THEM CLOSER TO THE WALL.** Slide the indoor legs in until they contact the inside wall or the indoor windowsill. Secure the indoor legs in place with 2 of the screws included in the hardware bag.

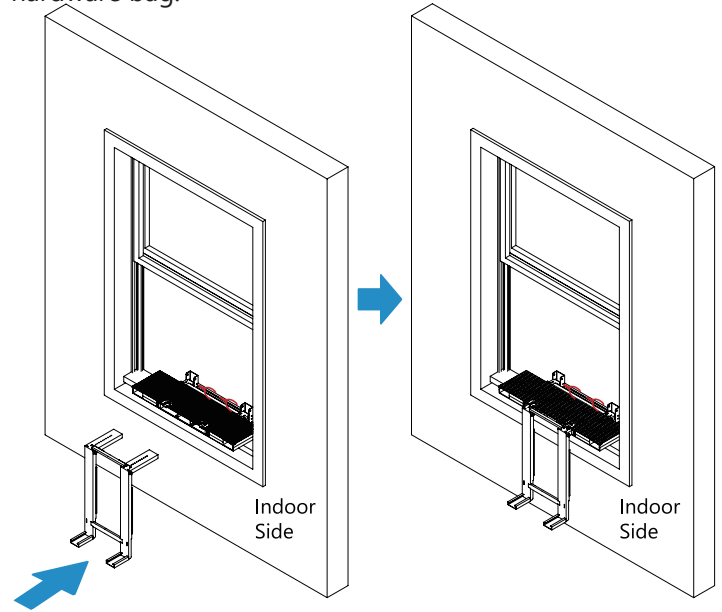


Fig. 11

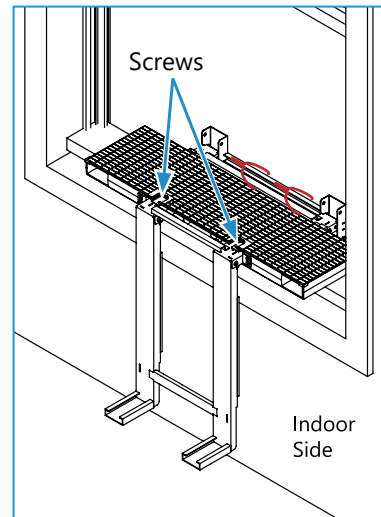
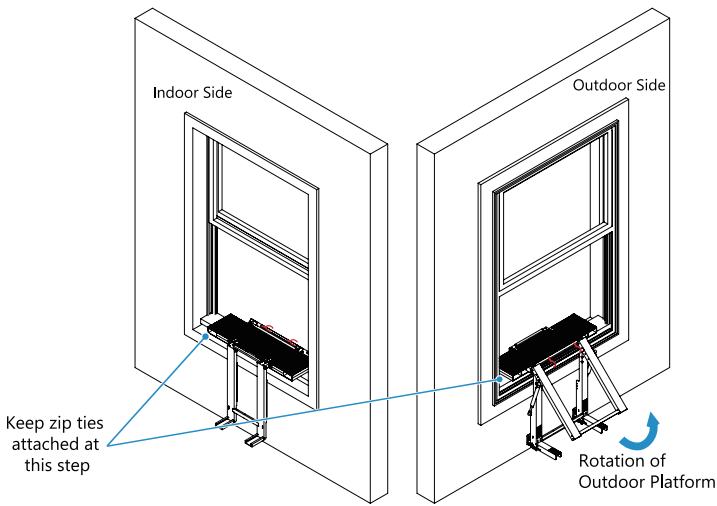


Fig. 11a

### 4 - Install Main Bracket – Final Steps

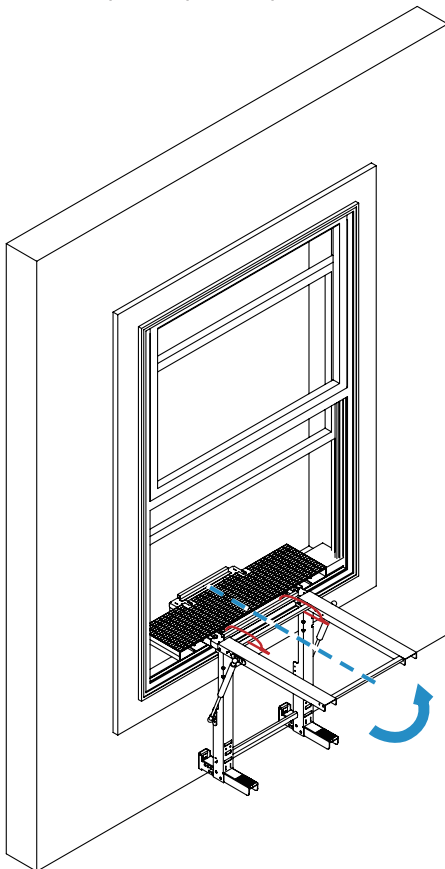
A. Prepare the outdoor side of the bracket for unit installation by installing the tapered hinge pins. **KEEP THE ZIP TIES CONNECTED AT THIS STEP.** With the zip ties still in place, pivot the support legs 90 degrees so

that they are parallel to the bracket seat.

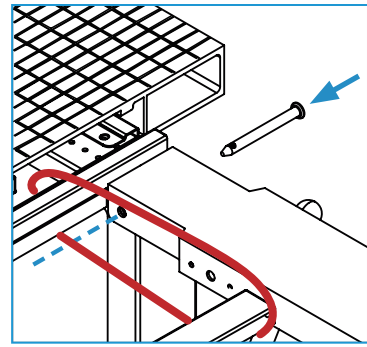


**Fig. 12**

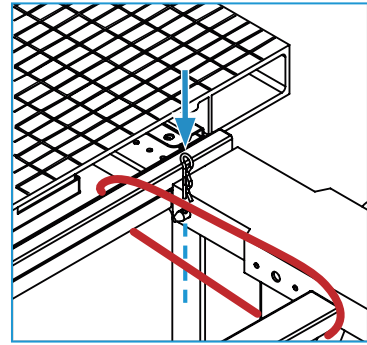
B. Line up the holes on the ends of the support legs to the holes on the outdoor legs and install the two tapered pins included in the hardware bag. Install the cotter pins to secure the tapered pins in place.



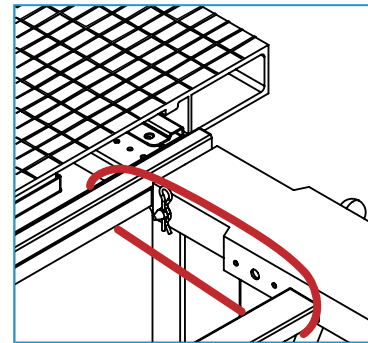
**Fig. 13**



**Fig. 13a**

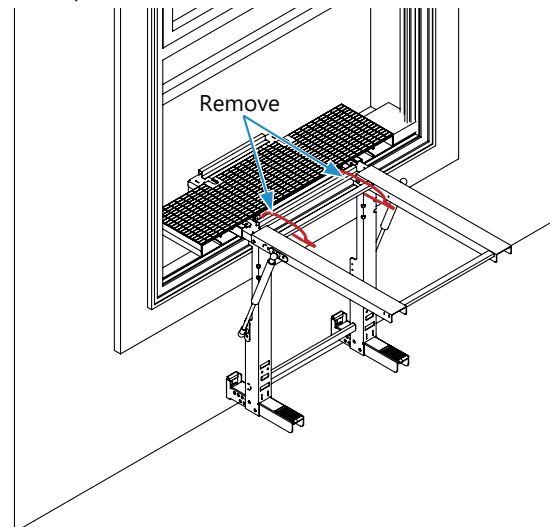


**Fig. 13b**



**Fig. 13c**

C. Once the tapered hinge pins have been installed and the support legs are secured in place, cut and remove the zip ties.



**Fig. 14**

## 5 - Install the Unit

- A. Measure the distance between the edge of the indoor component of the bracket and the hinge. Note this as the distance the unit must span to rest on the bracket.

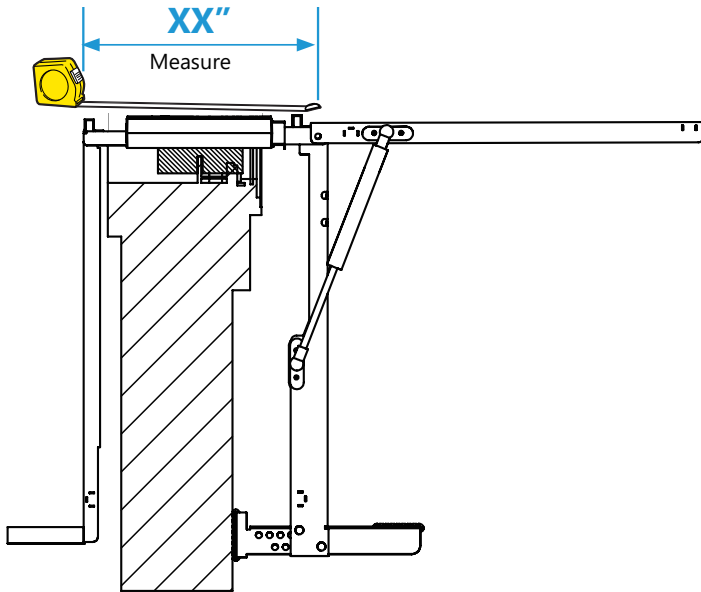


Fig. 15

- B. Remove the screw found at this location on both sides of the unit. With the help of a second person, adjust the distance between the indoor and outdoor components according to the distance measured on the bracket. Secure the distance by replacing and tightening the screws

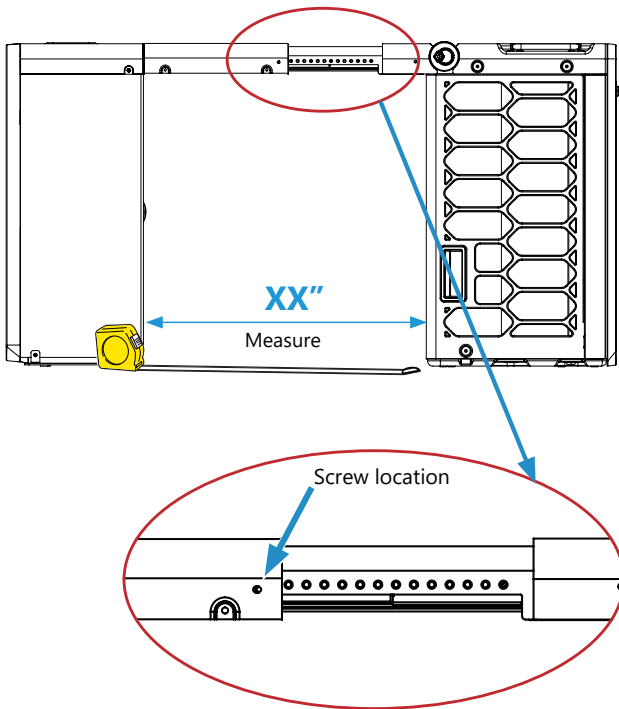


Fig. 16

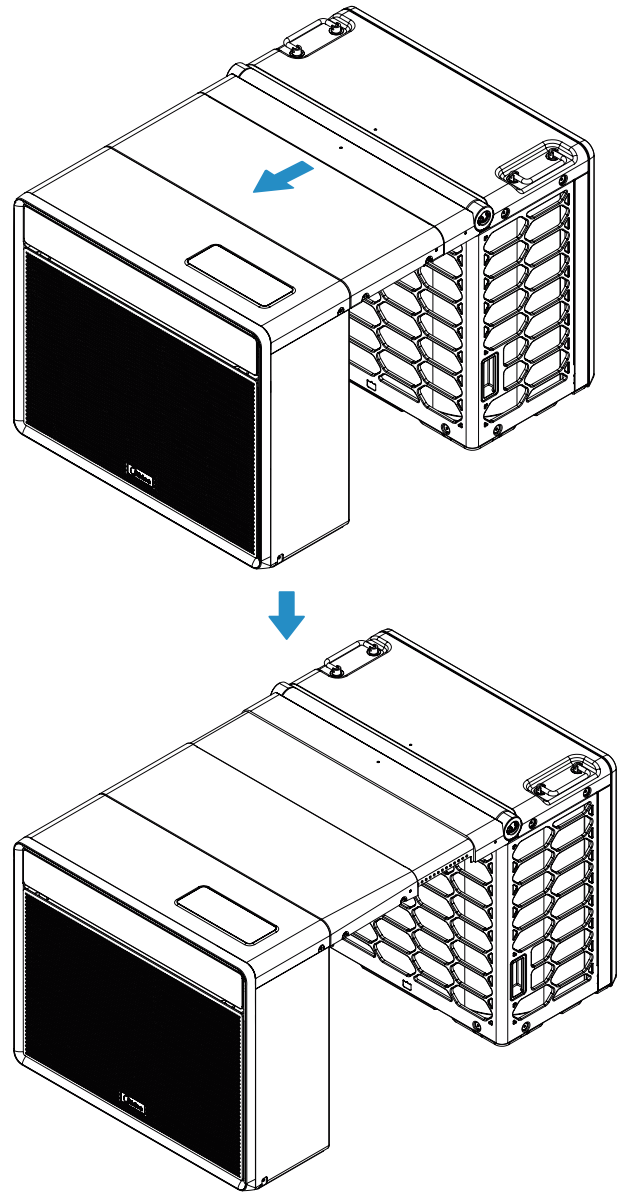


Fig. 17

C. Unlock the unit by pulling the pin located at the hinge. With the pin pulled and with the help of a second person, carefully lift the indoor component of the unit to pivot around the hinge 90 degrees. Tilt the unit to lay it on the ground in this new configuration.

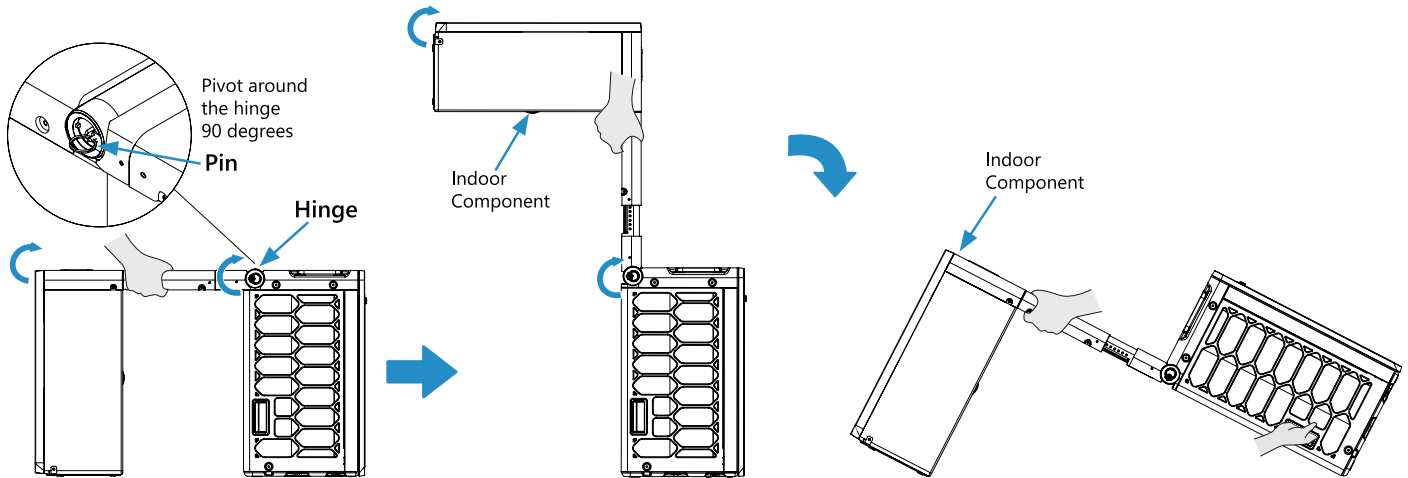


Fig. 18

D. CAREFULLY, WITH THE HELP OF A SECOND PERSON, lift the unit by the bridge near the indoor component and the handhold on the outdoor component. It is best to have one person on either side of the unit, with each person lifting at both the indoor and outdoor sides. Carefully carry the unit to the window, placing the outdoor component of the unit onto the seat and the outdoor support legs of the bracket.

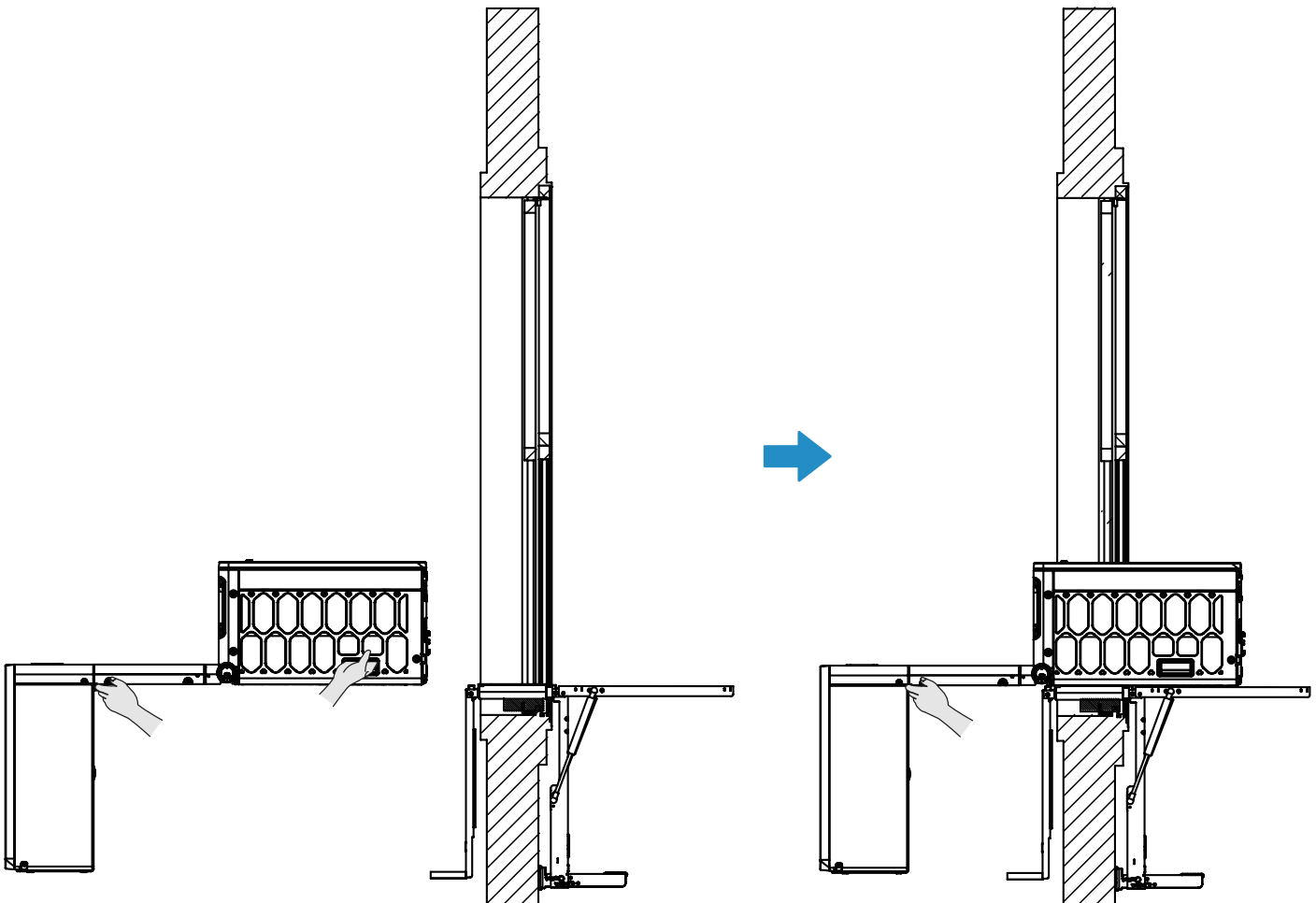


Fig. 19

E. Before pushing the unit further, keep one hand on the indoor component of the unit and, with the other hand, grab the handles on the top of the outdoor component.

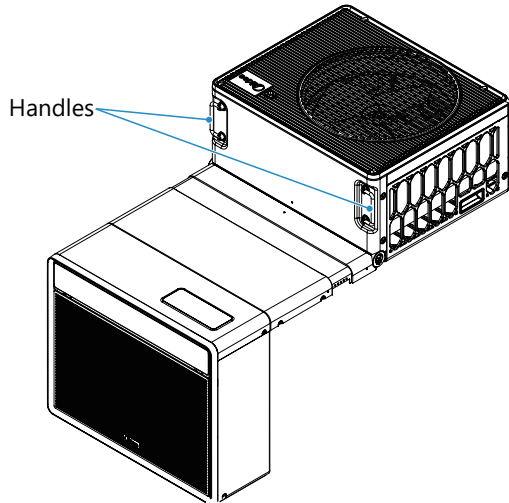


Fig. 20

**⚠ WARNING**

- Do not leave the unit unattended during installation.
  - The outdoor unit should not be left horizontally on the seat of the bracket for more than 3 minutes to protect the compressor.
- F. With a firm grip on the handles, continue to lift and slide the unit onto the platform of the bracket. The weight of the unit will cause the outdoor component to compress the shocks and slowly lower into place, as shown in the figures below.

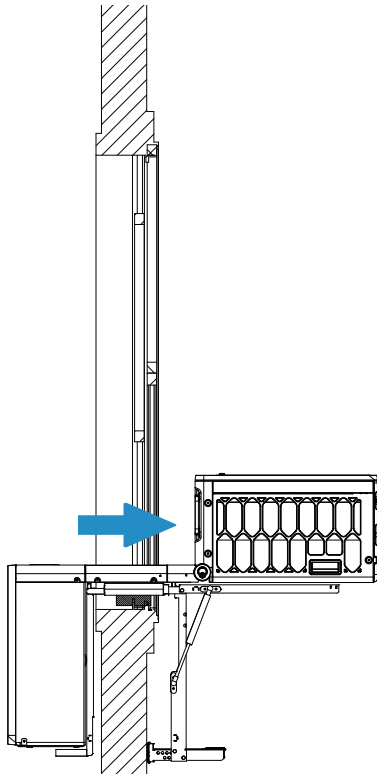


Fig. 21

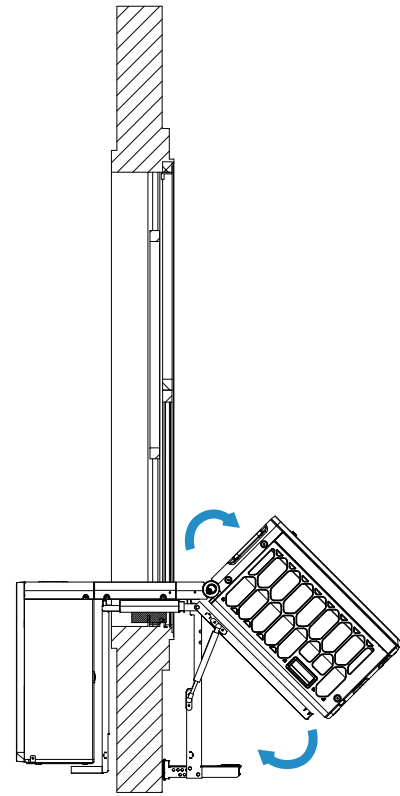


Fig. 22

**NOTE**

- Once fully rotated, the pin at the hinge will pop back into place, and the unit will again be locked in this position.
- After installation, it is recommended to let the unit stand for 10 minutes before turning it on.
- The unit needs to be installed horizontally.
- The unit will be installed at a slight angle, away from the window, per Step 2. Install Main Bracket – Outdoor Component D, as indicated in the figure below.

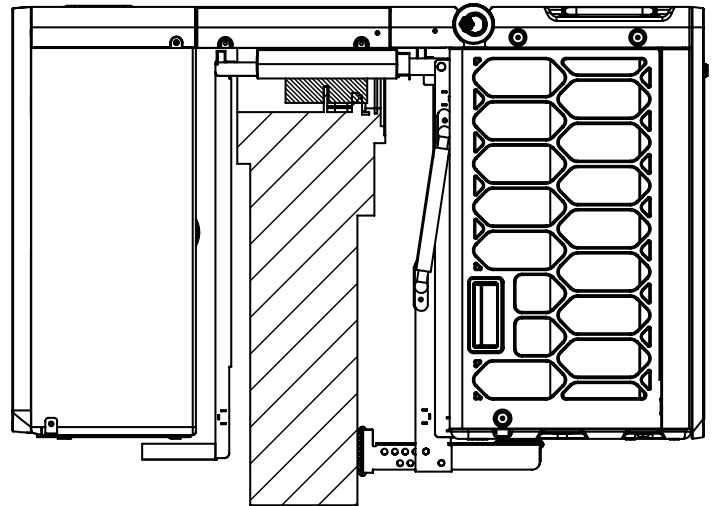


Fig. 23

## 6 - Foam Installation

A. With the unit installed on the Bracket Assembly, install the top sealing foam strip. Measure the distance from the sides of the unit to the window track on each side, shown as YY in figure below. Add 1/8 in. (~3mm) to this measurement. Cut top sealing foam strip, on both sides, to YY + 1/8 in. (~3mm).

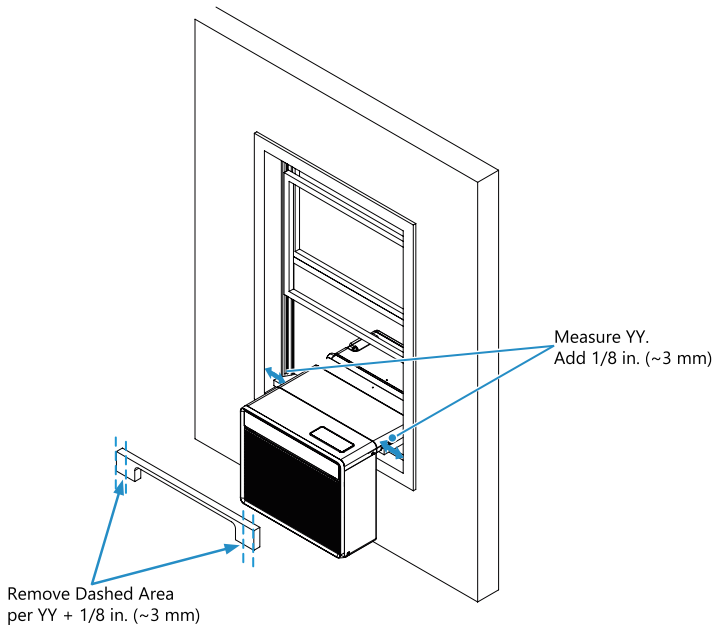


Fig. 24

B. With the top sealing foam strip cut to size, place it on top of the unit. Make sure that the sides of the foam strip are pressed into the window track so that the window will close directly onto the top sealing foam strip.

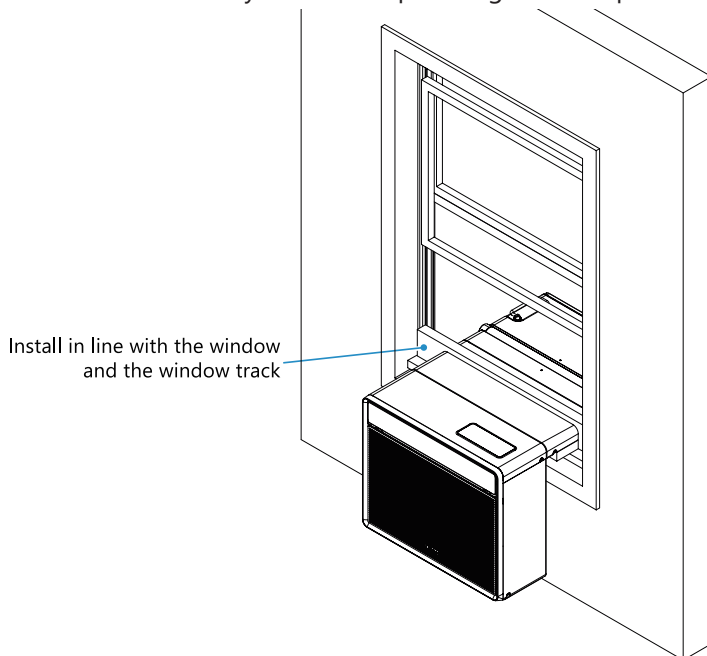


Fig. 25

C. Close the window and ensure all the foam seals are properly placed to seal around the unit. Using the adhesive foam, seal the space behind the open window sash. Fold the adhesive foam in half lengthwise to

Packaged Window Heat Pump

increase the thickness and add more layers of foam if needed to match the width of the gap between the window sashes. Press the foam into the gap to seal the window from any air leakage.

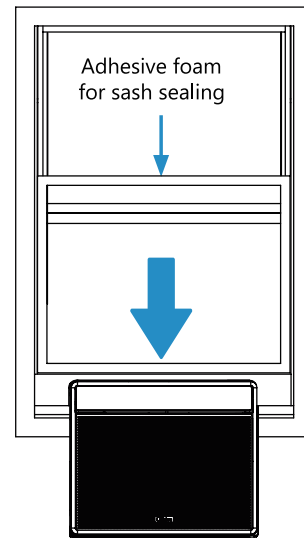


Fig. 26

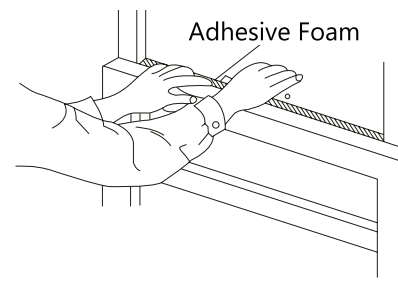


Fig. 27

D. If needed, use the remaining adhesive foam to seal any gaps around any of the foam sealing already installed. With the window closed, visually inspect the seal around the edges of the unit. Pay attention to the areas indicated in the next figure.

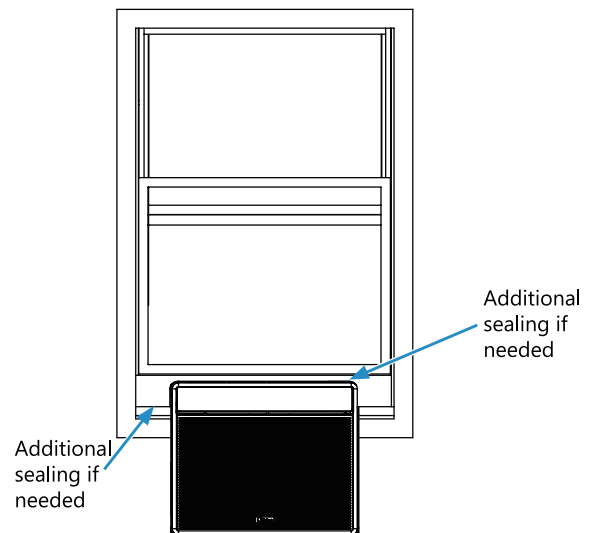


Fig. 28

E. Install the first window lock on the back windowpane in the center of the window. Ensure the front windowpane is lowered onto the sealing kit. Remove the adhesive backing from the first plastic window lock and place the plastic window lock so that the hinge is just below the front window sash.

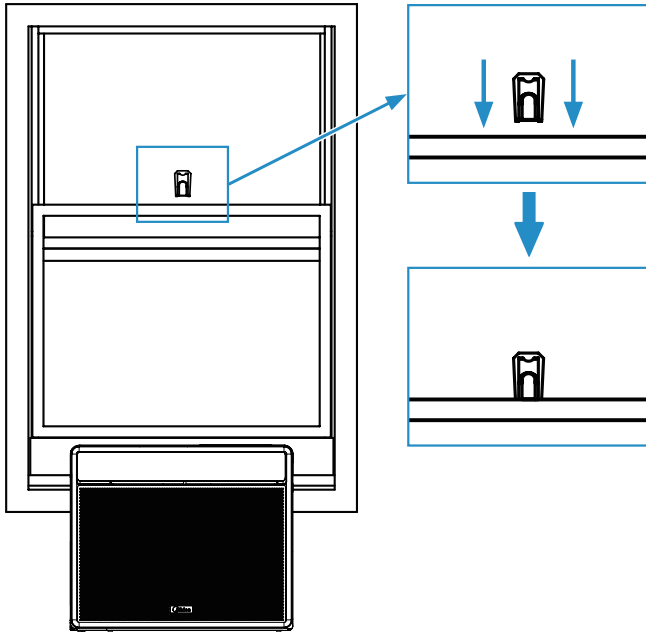


Fig. 29

F. Install the other two window locks on either side of the first, adhering again to the back windowpane. Make sure to install each lock with the hinge just below the front window sash.

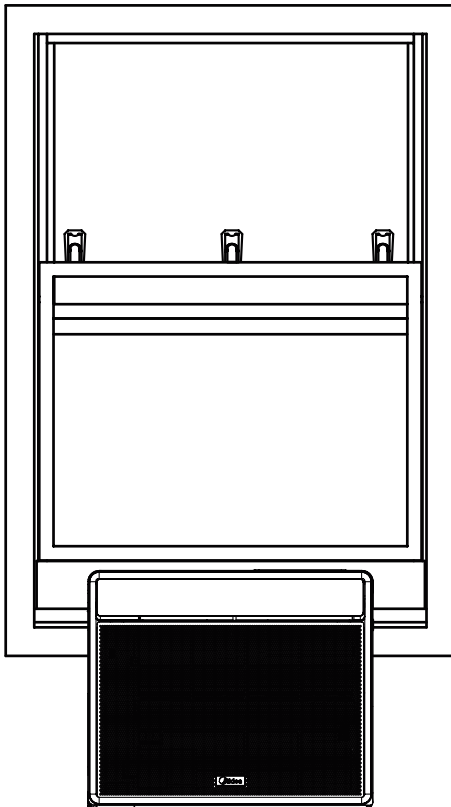


Fig. 30

G. Flip down the tab on all three window locks to secure the front window sash in place.

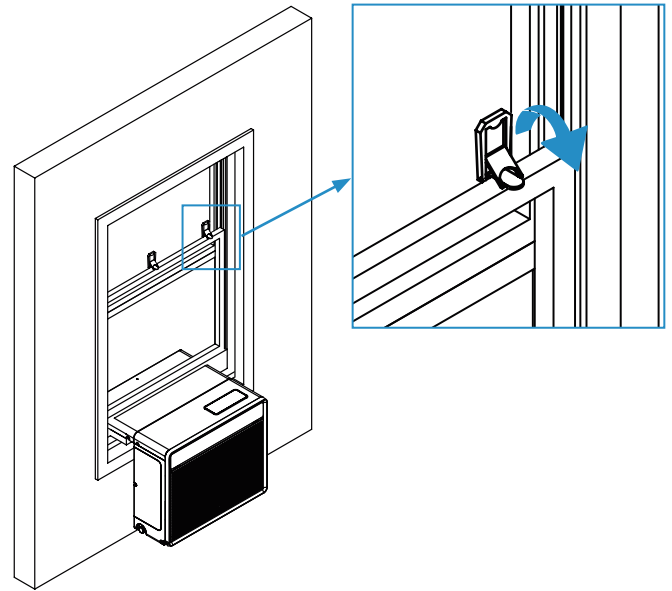


Fig. 31

H. Install the window lock to ensure the window stays closed during operation. Window locks can be attached to the back window sash frame or the side of the window. Use 2 screws from the hardware bag to secure the window lock to the window frame, drilling 1/8" pilot holes into the frame beforehand if needed.

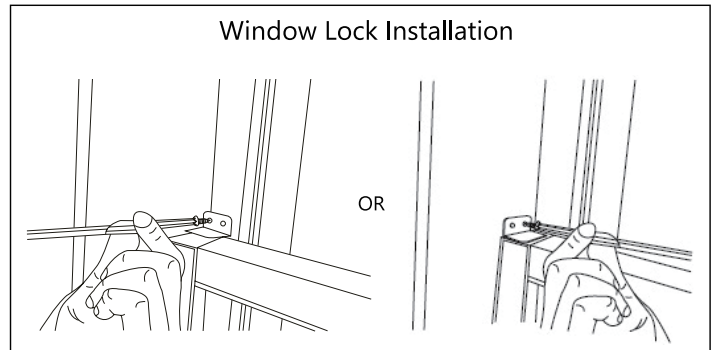


Fig. 32

# Operation Instructions

## Normal Sounds

### High-Pitched Chatter

High-efficiency compressors may have a high-pitched sound during the cooling cycle.

### Sound of Water Misting

A misting sound may be heard as a nozzle located on the outdoor side of the unit mists out any accumulated condensation.

### Humming Sound

A humming sound may be heard as the water pump removes excess condensate by pumping it into the nozzle.

### Click Sound

A click sound may be heard when the unit enters a defrost cycle.

### Vibration

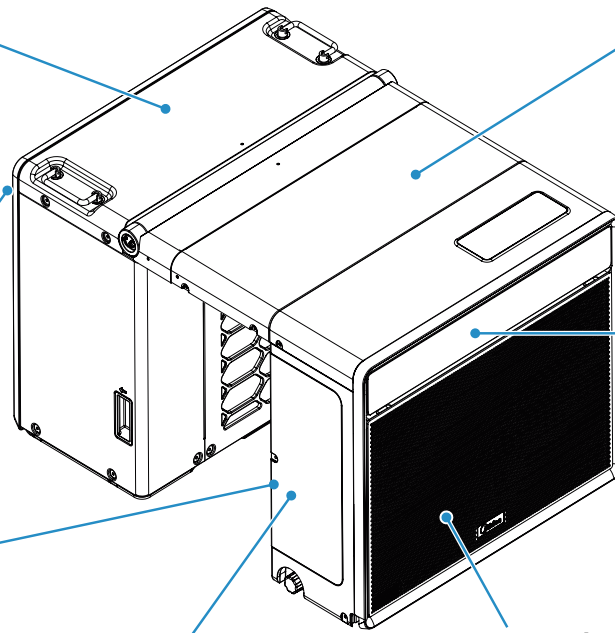
The unit may vibrate and make noise because of poor wall or window construction or incorrect installation.

### Sound of Rushing Air

In front of the unit, you may hear the sound of rushing air being moved by the fan.

### Gurgle/Hiss

Gurgling or hissing noises may be heard due to refrigerant flowing through the evaporator during normal operation.



## Sound Performance

The following table shows the sound performance data for these window units.

Please use your specific model number to reference the correct sound power number in the table.

Model Number	Sound Power, dB(A)*
MAH09S1AGR / MAH09H1AGR	39

\* Per ISO 3744 at silent fan speed

### NOTE

All the illustrations in this manual are for explanatory purposes only. The actual appearance may vary.

# Unit Operation

## **WARNING**

To reduce the risk of fire, electrical shock, or injury to people or property, read the SAFETY PRECAUTIONS before operating this appliance.

Operation Mode	Temperature Range
Cooling Operation	Outdoor temp.: 32°F ~ 122°F / 0°C ~ 50°C
	Indoor temp.: 60°F ~ 90°F / 16°C ~ 32°C
Heating Operation	Outdoor temp.: -13°F ~ 86°F / -25°C ~ 30°C
	Indoor temp.: 45°F ~ 86°F / 7°C ~ 30°C

### **NOTE**

- The relative humidity of the room should be less than 80%. If the unit is used in a condition with a relative humidity over 80%, there will be condensed water on the surface of the unit.
- Performance may be reduced outside of these operating temperatures.

### **NOTE**

Always wait 3 minutes when turning the unit off and then on again, or when changing between cool, fan, and heat. This prevents damage from occurring to the compressor.

#### **To Begin Operating The Unit, Follow These Steps:**

1. Plug in the unit (be sure to follow the power cord instructions).
2. Turn the power on to the unit, using the power button.
3. Select either the Cool or Heat mode setting depending

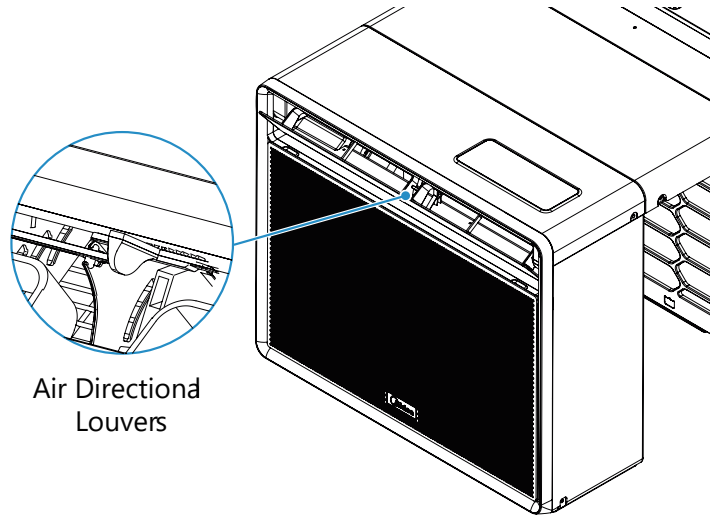
on preference and adjust the thermostat to the setting you find most comfortable.

4. Adjust the louver for comfortable air flow (see Air Directional Louvers).
5. Make sure the air flow inside and outside is not obstructed by anything.

## Air Directional Louvers

The louver will allow you to direct the air flow up or down as needed. Use the SWING button until the desired up/down direction is obtained.

Move the louvers from side to side by hand until the desired left/right direction is obtained.

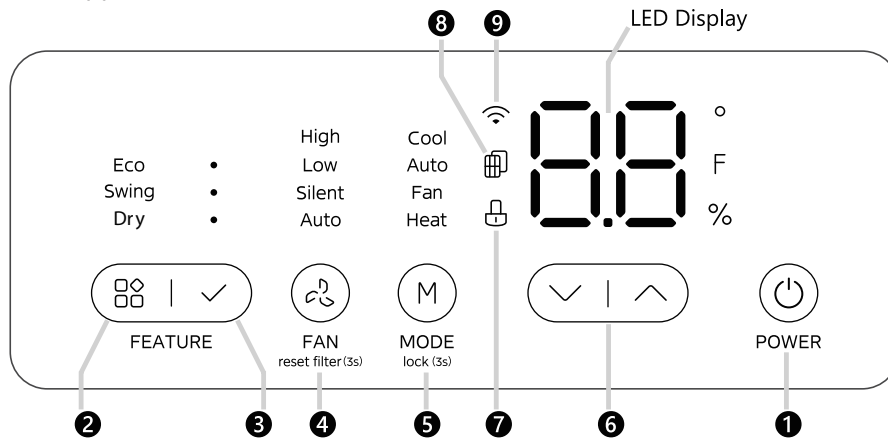


Air Directional Louvers

# Unit Features

## Electronic Control Operating Instructions

Before you begin, thoroughly familiarize yourself with the control panel as shown below and all its functions, then follow the symbols for the functions you desire. The unit can be controlled by the control panel, and, with units equipped with Wireless, by the smartphone app.



Callout Number	Control Icon	Description
1	Power Button	• Press to turn the unit on or off.
2	Feature - Scroll	• Press to scroll through available features
3	Feature - Select	• Press to toggle the highlighted features on/off
4	Fan Speed/ Check Filter Feature	• Press to select the Fan Speed in four steps – High, Low, Silent, Auto. • Press and hold for 3 seconds to reset the cleaning filter reminder.
5	Mode Functions/ Control Lock	• Press to choose an operating mode in a sequence that goes from Heat, Auto, Cool, and Fan. • Press and hold for 3 seconds to enable the control lock feature.
6	UP / DOWN Button	• Press to adjust set points for temperature and humidity.
7	Lock Icon	• The icon appears to indicate the UI control lock has been enabled.
8	Check Filter Icon	• The icon appears to indicate the air filter needs to be cleaned.
9	Connect Icon	• Icon appears to indicate the wireless module has been activated.

### 1 Power Button

Press the ON/OFF button to turn the unit on or off.

### 2 Feature - Scroll Button &

### 3 Feature - Select Button

- To choose a feature, press the Feature – Scroll button. Each time you press the button, a feature is selected in a sequence that goes Schedule, ECO, Swing, and Dry. The current feature in the sequence will be illuminated.
- To enable the feature, press the Feature – Select button when the desired feature is illuminated. Pressing the Feature – Select button once will turn on the indicator light next to the feature name, indicating that it is enabled. Press the Feature Select button again to disable the feature and turn the indicator light off. All features can be enabled at the same time.

### DRY feature

- Enabling the Dry feature will display the room humidity on the LED display. Choose the desired humidity using the UP (^) or DOWN (v) button. This feature can be enabled in Cooling mode.

### SWING feature

Enabling the Swing feature will initiate the auto swing feature for the outlet louver. When the auto swing is on, disabling Packaged Window Heat Pump

the SWING feature can stop the louver at the desired angle. ECO feature

- Enabling the ECO feature will allow you to run the unit in an energy-saving mode while operating on Auto and Cool modes. The unit will automatically initiate the ECO function under Cool mode and Auto mode.
- With the ECO feature enabled, the fan will continue to run for 3 minutes after the compressor shuts off upon reaching the set temperature. The fan then cycles on for 2 minutes at 10-minute intervals until the difference between the room temperature and set temperature is 2°F, at which time the compressor turns back on, and heating or cooling starts.

### 4 FAN SPEED Button

Press the Fan button to select the Fan Speed in four steps - Auto, Silent, Low, and High. Each time the button is pressed, the fan speed mode is shifted.

### Check Filter Feature:

The Check Filter feature is a reminder to clean the air filter for a more efficient operation. The light above the button will illuminate after 250 hours of operation. After cleaning the filter, press the **FAN** button for 3 seconds to reset the Check Filter feature, turning the light off.

### Network Connection:

To connect the unit to wireless, press and hold the Power buttons simultaneously for 3 seconds. You will hear a beep and see the indicator light flash on the User Interface, indicating that the wireless module has been activated, and you can connect to the app.

### 5 MODE Button

- To choose the operating mode, press the **MODE** button. Each time you press the button, a mode is selected in a sequence that goes from Heat, Auto, Cool, and Fan. The mode function will be illuminated and remain on once that mode is selected.
- The Control Lock Feature allows you to lock the User Interface, preventing accidental button presses on the User Interface from children or pets. Press and hold the **MODE** button for 3 seconds to activate the Control Lock feature. Press and hold the **MODE** button again for 3 seconds to turn off the Control Lock feature.

#### To operate in **HEAT** mode:

- Choose Heat Mode to set the heating function. Use the **UP** (∧) or **DOWN** (∨) buttons to choose the desired temperature. When Heat Mode is selected, the fan speed can be adjusted by pressing the fan button.

#### To operate in **AUTO** mode:

- When you set the unit to Auto mode, it will automatically select cooling, heating, or fan-only operation, depending on what temperature you have selected and the current room temperature.
- The cooling mode will be selected when the room temperature is 4°F (2°C) above the selected set temperature. The heating mode will be selected when the room temperature is 4°F (2°C) below the selected set temperature. When the room temperature is less than 4°F (2°C) above or below the selected set temperature, the unit will run in fan-only mode.
- The unit will automatically control the room temperature according to the temperature you've set.
- In this mode, the fan speed cannot be adjusted and is automatically controlled based on the temperature setting and room temperature.

#### To operate in **COOL** mode:

- Choose Cool Mode to set the cooling function. Use the **UP** (∧) or **DOWN** (∨) buttons to choose the desired temperature. When Cool Mode is selected, the fan speed can be adjusted by pressing the fan button.

#### To operate in **FAN** mode:

- Use this function only when heating or cooling is not desired, such as for room air circulation. You can choose any fan speed you prefer.
- In Fan Only mode, the temperature cannot be adjusted, and the display will show the actual room temperature, not the set temperature as in the heating or cooling mode.

### 6 UP/DOWN Button

Press the **UP** (∧) or **DOWN** (∨) button to change temperature setting.

### LED Displays

#### LED Display:

Shows the set temperature in "°C" or "°F" and indication icons for the included features. While on Fan Only mode,

it shows the room temperature. If the room temperature is too high or low, it will display "99°F (37°C)" or "32°F (0°C)". To change between °F and °C, press and hold the **UP** (∧) and **DOWN** (∨) buttons at the same time for 3 seconds.



### Error Codes:

The unit may stop operation due to a malfunction with the unit. If this occurs, an error code may appear on the display. Wait 10 minutes as the problem may resolve itself. If not, turn the unit off and unplug it, then plug the unit back in and restart it. If the problem persists, disconnect the power and contact customer service. Please see the list of error codes associated with this unit.

### NOTE

If the unit turns off unexpectedly due to the power being cut, it will automatically restart with the previous function setting when the power resumes.

## Connection

## Instructions

## Declaration of Conformity

FCC ID: 2ADQOMDNA23

IC: 12575A-MDNA23

This device complies with Part 15 of the FCC Rules and Industry Canada's license-exempt RSSs.

Operation is subject to the following two conditions.

1. This device may not cause interference, and
2. This device must accept any interference, including interference that may cause undesired operation of the device.

Only operate the device in accordance with the instructions supplied. Changes or modifications to this unit that are not expressly approved by the party responsible for compliance could void the user's authority to operate the equipment. This device complies with FCC radiation exposure limits set forth for an uncontrolled environment. To avoid the possibility of exceeding the FCC radio frequency exposure limits, human proximity to the antenna shall not be less than 8 in. (20 cm) during normal operation.

### NOTE

The equipment has been tested and found to comply with the limits for a Class B digital device, pursuant to Part 15 of the FCC Rules. These limits are designed to provide reasonable protection against harmful interference in a residential installation. This equipment generates, uses, and can radiate radio frequency and, if not installed and used in accordance with the instructions, may cause harmful interference to radio communications. However, there is no guarantee that interference will not occur in a particular installation. If this equipment does cause harmful interference to radio or television reception, which can be determined by turning

the equipment off and on, the user is encouraged to try to correct the interference by one or more of the following measures:

- Reorient or relocate the receiving antenna.
- Increase the separation between the equipment and the receiver.
- Connect the equipment to an outlet on a circuit different from that to which the receiver is connected.
- Consult the dealer or an experienced radio/TV technician for help.

### Specification of the Wireless Module

Model: US-SK109
Antenna Type: Printed PCB Antenna
Frequency: WLAN 2400-2483.5 MHz
Maximum Transmitted Power: <20 dBm Max
Dimensions: 1.6 x 0.9 x 0.2 (in)
Operation Temperature: 32°F ~ 113°F / 0°C ~ 45°C
Operation Humidity: 10% ~ 85%
Power Input: DC 5V/300 mA
Maximum Transmitted Power: BLE < 10dBm

### How To Use The SmartHome App


**⚠ CAUTION**

Ensure that your mobile phone is connected to the wireless network. Bluetooth must be turned on.

1. Download the SmartHome App  
Scan the QR code below to download the SmartHome app from the App Store or search for it directly on the Google Play Store or Apple’s App Store.



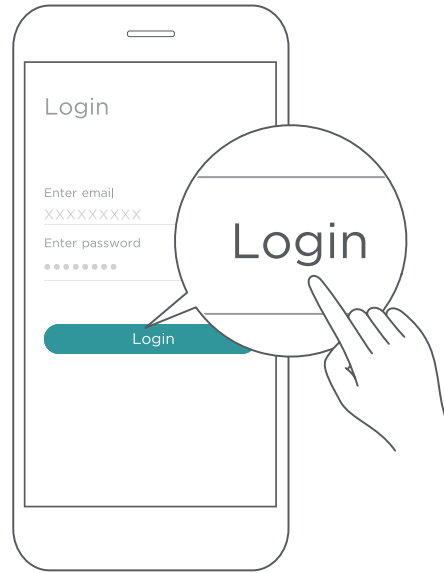
**SmartHome**



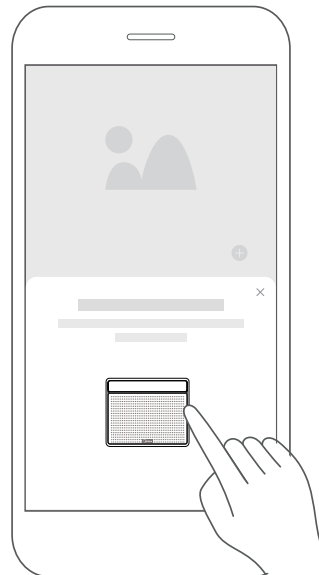
Download the app  
& activate product



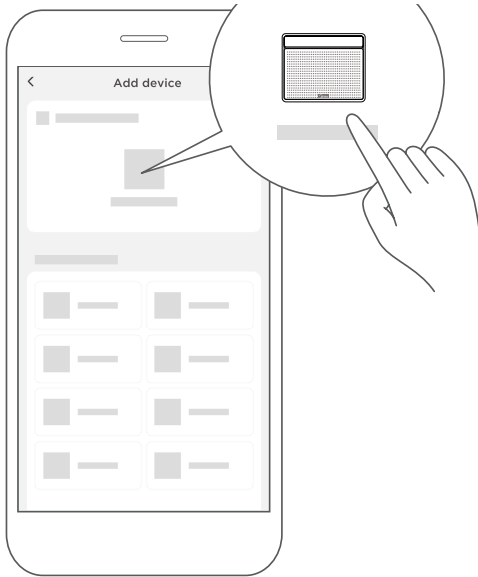
2. Log in  
Open the SmartHome app. Log in directly if you have an existing SmartHome account or create a new account. Alternatively, you can also use a 3rd party login platform.



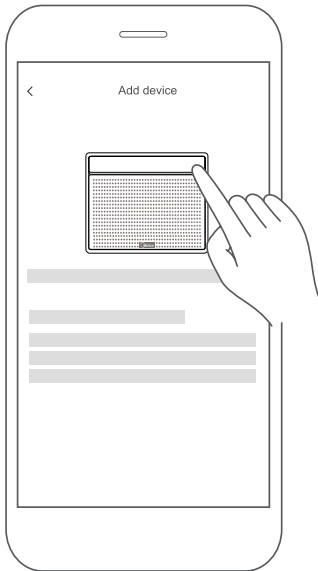
3. Connecting the Device  
A. When you log in, you may see the message “Smart devices discovered nearby”. Tap to add your device.



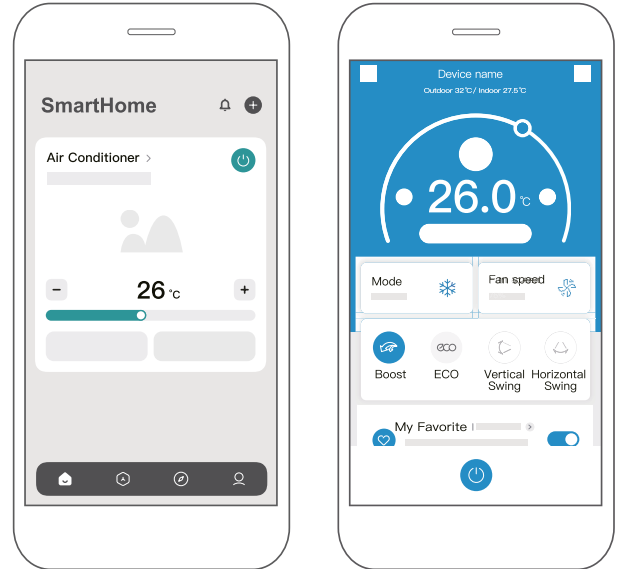
- B. If no such message appears, proceed as follows: Tap on "+" and select your device in the list of nearby available devices.  
If your device is not listed, please add your device manually, RST selecting the device category e.g., Window AC.



- C. Follow the steps in the app to connect your device to the wireless network. If your device fails to connect, follow the additional instructions in the app.



- D. Controlling the Device  
After pairing successfully, a card will be created for the device in the SmartHome app. Shortcuts for basic functions will appear on the card, such as changing the temperature or switching the device on or off.  
Tapping on the card, will reveal additional features and settings. The actual UI design may look different from examples due to app updates.

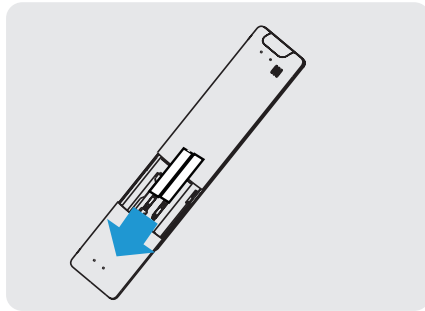


# Remote Control Operation

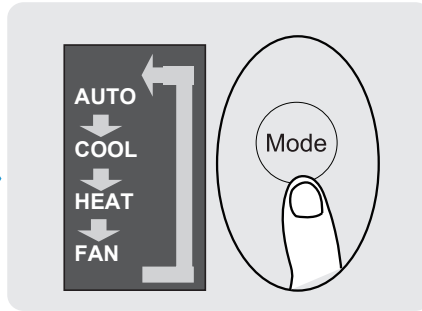
<b>Model</b>	RG10G6(B2)/BGEFU1
<b>Rated Voltage</b>	3.0 V (Dry batteries R03/LR03×2)
<b>Signal Receiving Range</b>	26 1/4 ft. (8 m)
<b>Environment</b>	23°F~140°F (-5°C~60°C)

## Quick Start Guide

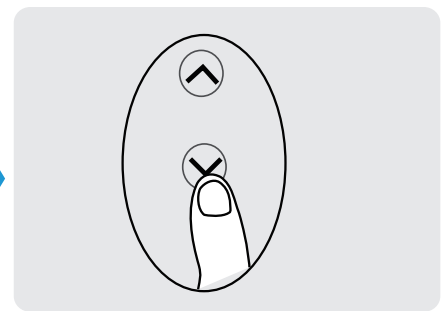
### 1 INSERT BATTERIES



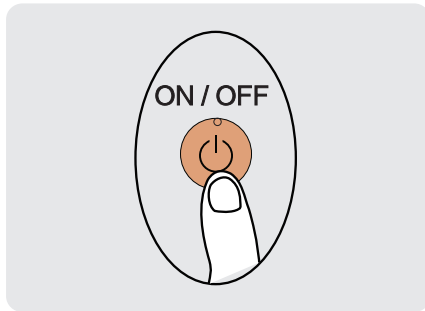
### 2 SELECT MODE



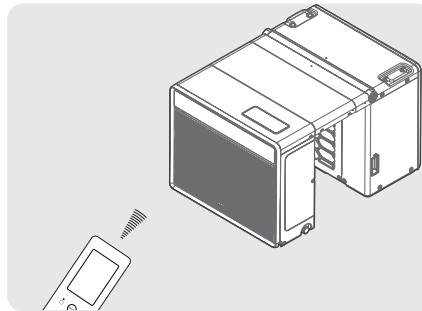
### 3 SELECT TEMPERATURE



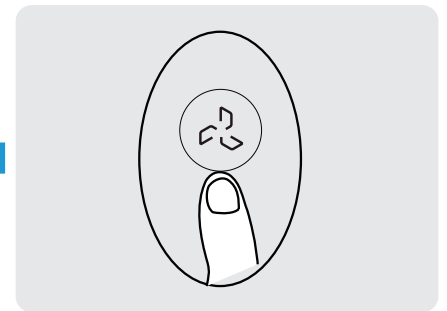
### 6 PRESS POWER BUTTON



### 5 POINT REMOTE TOWARD UNIT



### 4 SELECT FAN SPEED



### NOT SURE WHAT A FUNCTION DOES?

Refer to the How to Use Basic Functions and How to Use Advanced Functions sections of this manual for a detailed description of how to use your air conditioner.

### SPECIAL NOTE

- Button designs on your unit may differ slightly from the example shown.
- If the indoor unit does not have a particular function, pressing the corresponding button on the remote control will have no effect.

## Handling the Remote Control

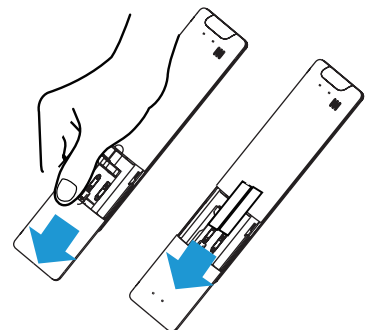
### Inserting And Replacing Batteries

Your air conditioning unit may come with two batteries (some units). Put the batteries in the remote control before use.

1. Slide the back cover of the remote control downward, exposing the battery compartment.
2. Insert the batteries, match the (+) and (-) ends of the batteries with the symbols inside the battery compartment.
3. Slide the battery cover back into place.

### Remote Control

- Direct sunlight can interfere with the infrared signal receiver.
- There must be a clear line of sight between the remote and the appliance.
- If the signals from the remote control happen to control another appliance, move the appliance to another location, or contact customer service.



## CAUTION

### Battery Disposal

- Do not dispose of batteries as unsorted municipal waste. Refer to local laws for proper disposal of batteries.
- Batteries may have a chemical symbol below the disposal icon. This chemical symbol means that the battery contains a heavy metal that exceeds a certain concentration.  
An example is Pb: Lead (>0.004%).
- Appliances and used batteries must be treated in a specialized facility for reuse, recycling, and recovery. By ensuring correct disposal, you will help avoid possible negative consequences for the environment and human health.



### Battery Performance

For optimal product performance:

- Do not mix old and new batteries, or batteries of different brands.
- Do not leave batteries in the remote control if you don't plan on using the device for more than 2 months.

## NOTE

### For Using The Remote Control

The device could comply with the local national regulations.

- In Canada, it should comply with CAN ICES-3(B)/NMB-3(B).
- In the USA, this device complies with part 15 of the

FCC Rules. Operation is subject to the following two conditions:

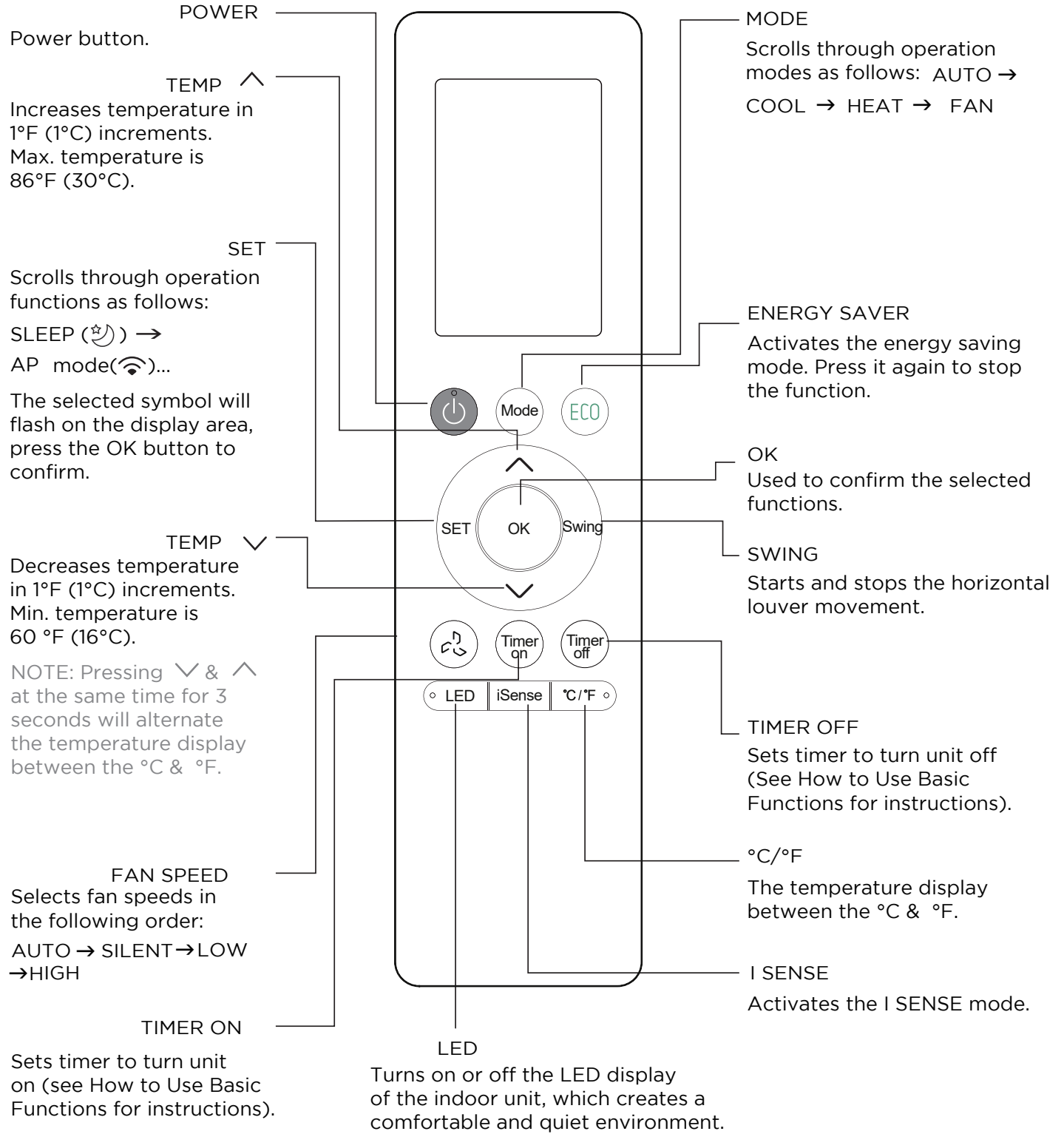
1. This device may not cause harmful interference, and
2. This device must accept any interference received, including interference that may cause undesired operation.

This equipment has been tested and found to comply with the limits for a Class B digital device, pursuant to part 15 of the FCC Rules. These limits are designed to provide reasonable protection against harmful interference in a residential installation. This equipment generates, uses, and can radiate radio frequency energy and, if not installed and used in accordance with the instructions, may cause harmful interference to radio communications. However, there is no guarantee that interference will not occur in a particular installation. If this equipment does cause harmful interference to radio or television reception, which can be determined by turning the equipment off and on, the user is encouraged to try to correct the interference by one or more of the following measures:

- Reorient or relocate the receiving antenna.
- Increase the separation between the equipment and receiver.
- Connect the equipment to an outlet on a circuit different from that to which the receiver is connected.
- Consult the dealer or an experienced radio/TV technician for help.
- Changes or modifications not approved by the party responsible for compliance could void the user's authority to operate the equipment.

# Buttons And Functions

Before you begin using your new air conditioner, familiarize yourself with its remote control. The following is a brief introduction to the remote control itself. For instructions on operating your air conditioner, refer to the How to Use Basic Functions section of this manual.





# How To Use Basic Functions

## Basic Operation

**ATTENTION!** Before operating, please ensure the unit is plugged in and power is available.

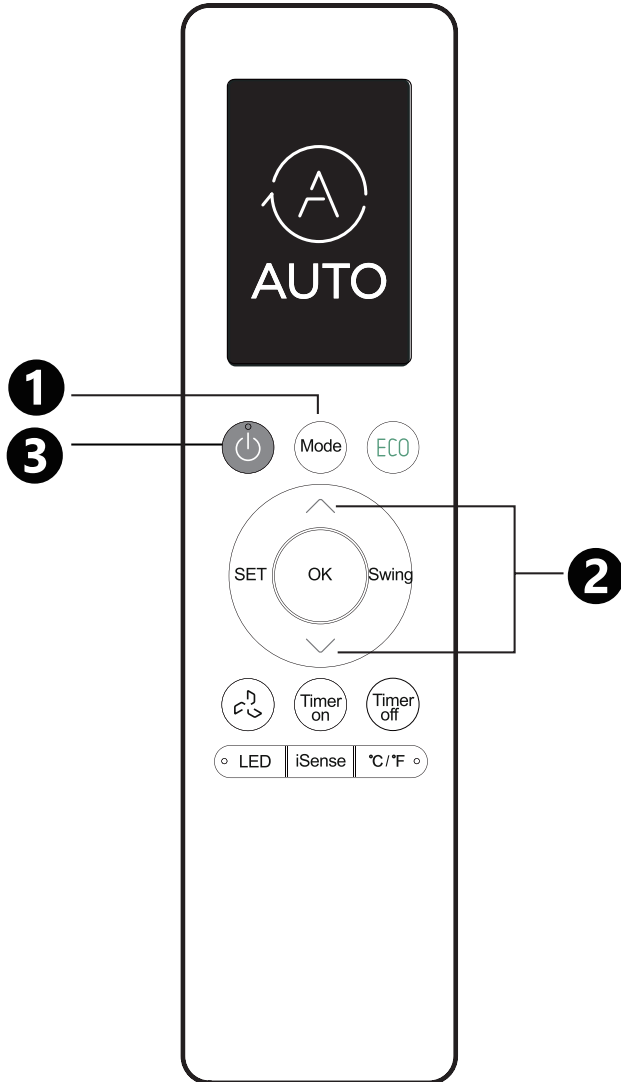
## Setting Temperature

The operating temperature range for units is 60-86°F (16-30°C).

You can increase or decrease the set temperature in 1°F (1°C) increments.

## AUTO Mode

In AUTO mode, the unit will automatically select the COOL, FAN, or HEAT function based on the set temperature.

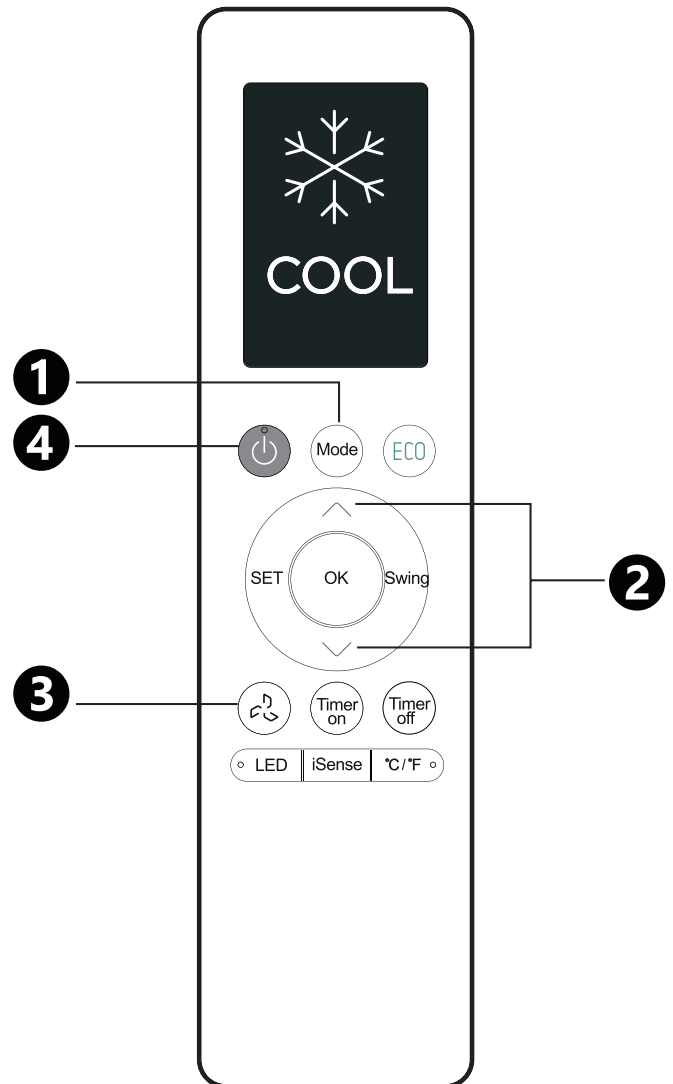


- 1 Press the **MODE** button to select **AUTO**.
- 2 Set your desired temperature using the **TEMP ▲** or **TEMP ▼** button.
- 3 Press the **POWER** button to start the unit.

## NOTE

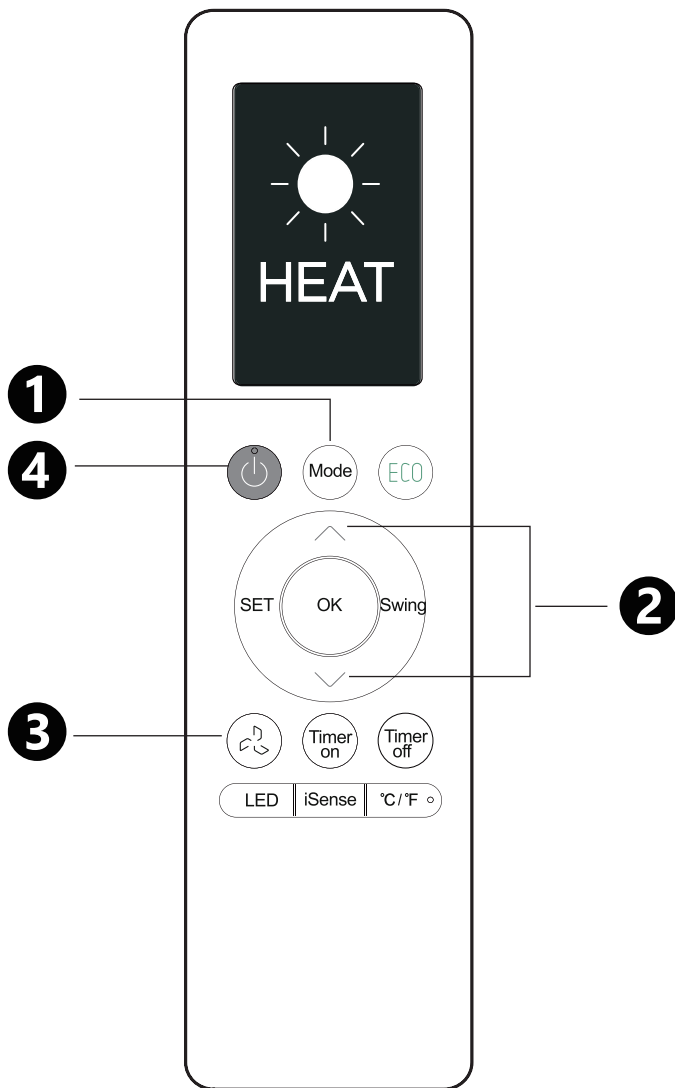
**FAN SPEED** can't be set in **AUTO** mode.

## COOL Mode

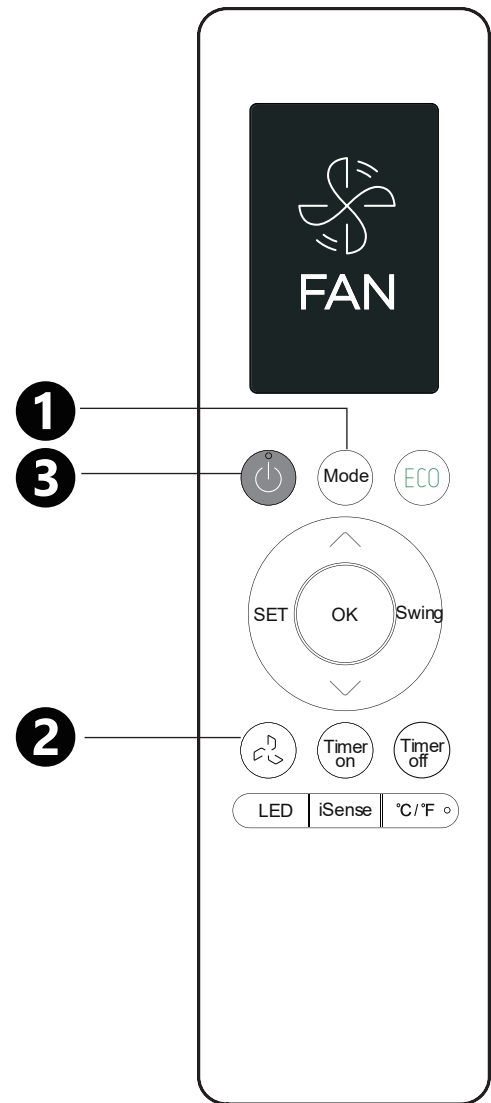


- 1 Press the **Mode** button to select **COOL** mode.
- 2 Set your desired temperature using the **TEMP ▲** or **TEMP ▼** button.
- 3 Press the **FAN** button to select the fan speed: **AUTO**, **SILENT**, **LOW**, and **HIGH**.
- 4 Press the **POWER** button to start the unit.

## HEAT Mode



## FAN Mode



- 1 Press the **Mode** button to select **HEAT** mode.
- 2 Set your desired temperature using the **TEMP ▲** or **TEMP ▼** button.
- 3 Press the **FAN** button to select the fan speed: AUTO, SILENT, LOW, and HIGH.
- 4 Press the **POWER** button to start the unit.

### NOTE

As outdoor temperature drops, the performance of your unit's HEAT function may be affected. In such instances, we recommend using this air conditioner in conjunction with other heating appliances.

- 1 Press the **Mode** button to select **FAN** mode.
- 2 Press the **FAN** button to select the fan speed: AUTO, SILENT, LOW, HIGH.
- 3 Press the **POWER** button to start the unit.

### NOTE

You can't set the temperature in FAN mode. As a result, your remote control's LCD screen will not display temperature.

# Setting The Timer

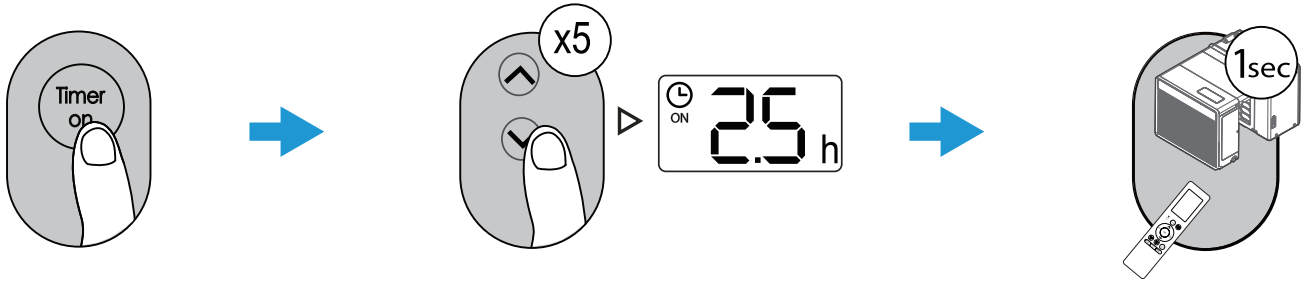
Timer on/off - Set the amount of time after which the unit will automatically turn on/off.

## Timer On Setting

Press the **TIMER ON** button to initiate the on-time sequence.

Press the up or down button multiple times to set the desired time to turn on the unit.

Point the remote at the unit and wait for 1 second, the **TIMER ON** will be activated.

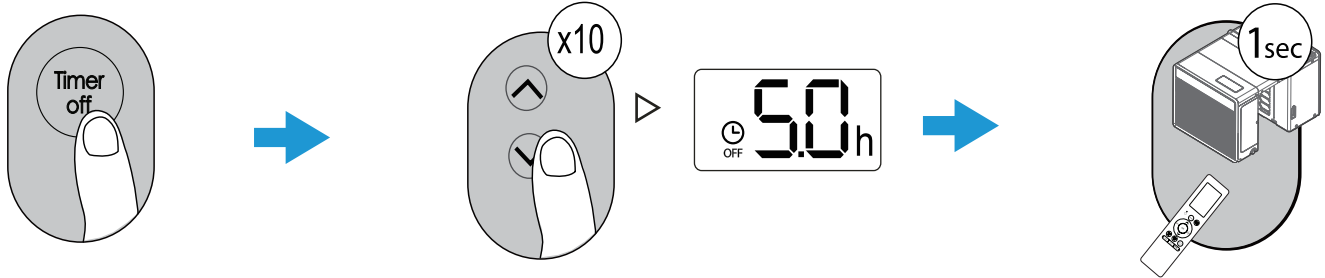


## Timer Off Setting

Press the **TIMER OFF** button to initiate the off-time sequence.

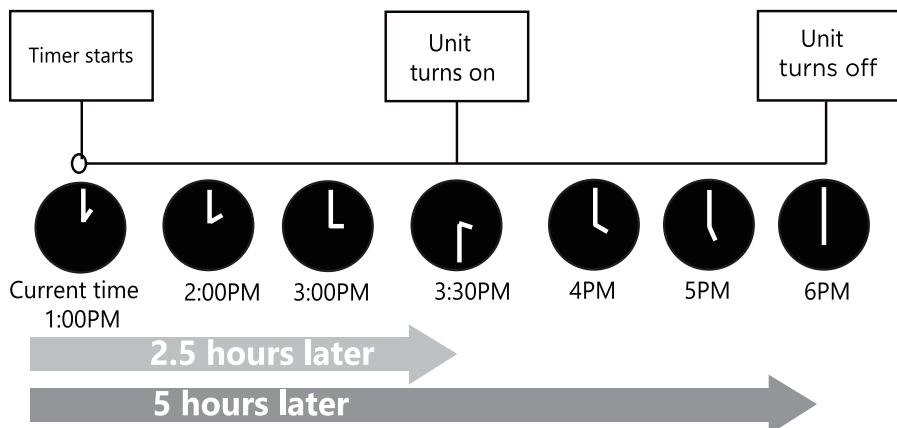
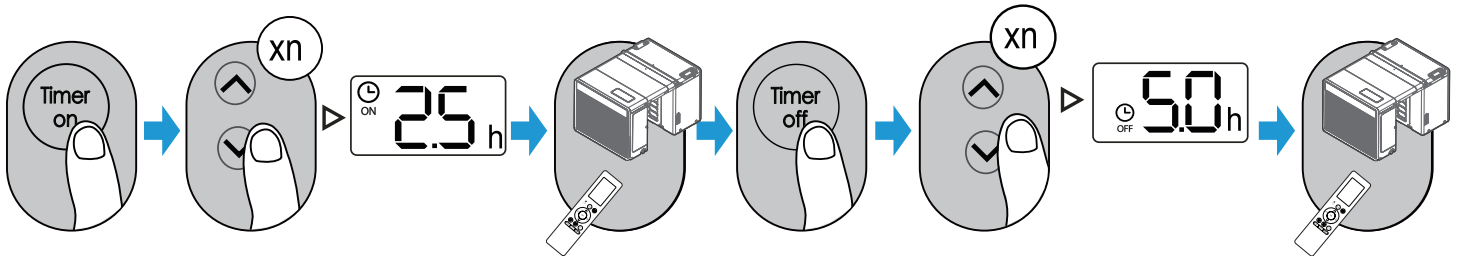
Press Temp. up or down button multiple times to set the desired time to turn off the unit.

Point the remote at the unit and wait for 1 second, the **TIMER OFF** will be activated.



## Timer On & Off Setting (Example)

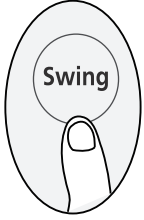
Keep in mind that the time you set for both functions refers to hours after the current time.



**Example:** If the current time is 1:00 PM, following the steps above will result in the unit turning on 2.5 hours later at 3:30 PM and turning off at 6:00 PM.

# How To Use Advanced Functions

## Swing Function



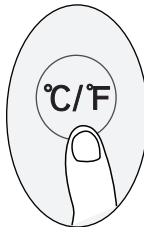
Press the **Swing** button  
The horizontal louver will swing up and down automatically when pressing the Swing button. Press again to make it stop.

## ECO Function



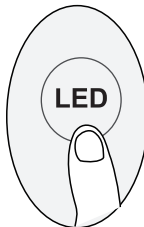
Press the **ECO** button to turn on this function. This function is available in COOL, AUTO modes.

## °C/°F Function



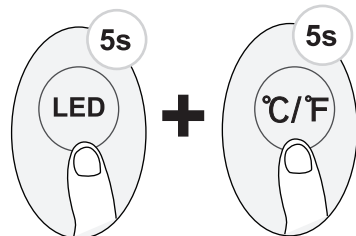
Pressing this button will alternate the temperature display between °C & °F.

## LED Display



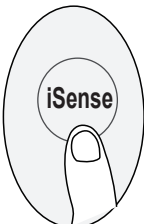
Press the **LED** button to turn on or off the display on the indoor unit.

## LOCK Function



Press the **LED** button and **°C/°F** button at the same time for more than 5 seconds to activate the Lock function. All buttons will not respond except pressing these two buttons for two seconds again to unlock.

## I SENSE Function



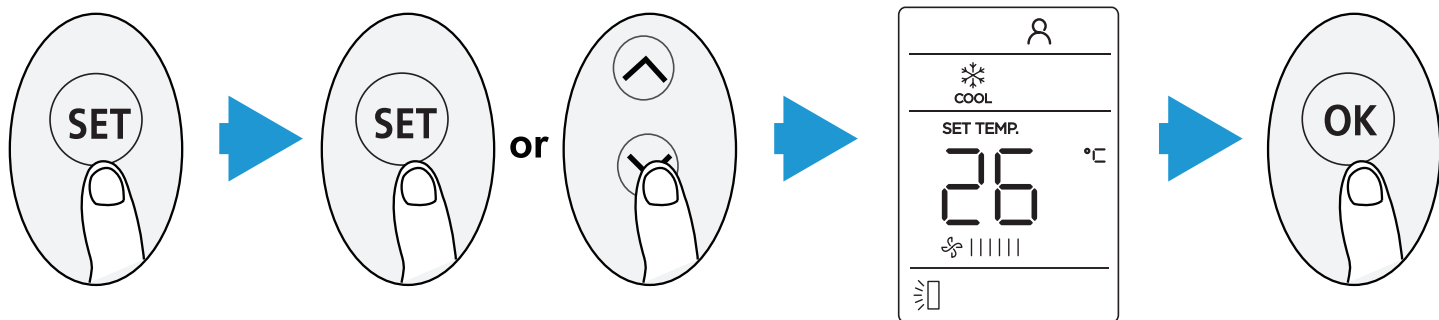
The **I SENSE** function enables the remote control to measure the temperature at its current location and send this signal to the air conditioner every 3-minute interval. When using AUTO, COOL, or HEAT modes, measuring ambient temperature from the remote control (instead of from the indoor unit itself) will enable the air conditioner to optimize the temperature around you and ensure maximum comfort.

### NOTE

Press and hold the **I SENSE** button for seven seconds to start/stop the memory feature of the **I SENSE** function.

- If the memory feature is activated, "**ON**" displays for 3 seconds on the screen.
- If the memory feature is deactivated, "**OFF**" displays for 3 seconds on the screen.
- While the memory feature is activated, press the **ON/OFF** button, shift the mode, or power failure will not cancel the **I SENSE** function.

## SET Function



Press the SET button to enter the function setting, then press the SET button, TEMP  $\nabla$  or TEMP  $\blacktriangle$  button to select the desired function. The selected symbol will flash on the display area. Press the OK button to confirm.

- To cancel the selected function, just perform the same procedures as above.
- Press the SET button to scroll through operation functions as follows: SLEEP (☾) → AP mode (📶)

## Sleep Function (☾):

The SLEEP function is used to save energy while you sleep (and don't need the same temperature settings to stay comfortable). This function can only be activated via the remote control.

### NOTE

The SLEEP function is not available in FAN or DRY mode.

## AP function (📶):

Choose the AP mode to configure the wireless network. For some units, you cannot enter the AP mode by pressing the SET button. To enter the AP mode, try pressing the LED button 7 times in 10 seconds.

# Cleaning And Maintenance

## ⚠ CAUTION

Clean your unit occasionally to keep it looking new. Be sure to unplug the unit before cleaning to prevent shock or fire hazards.

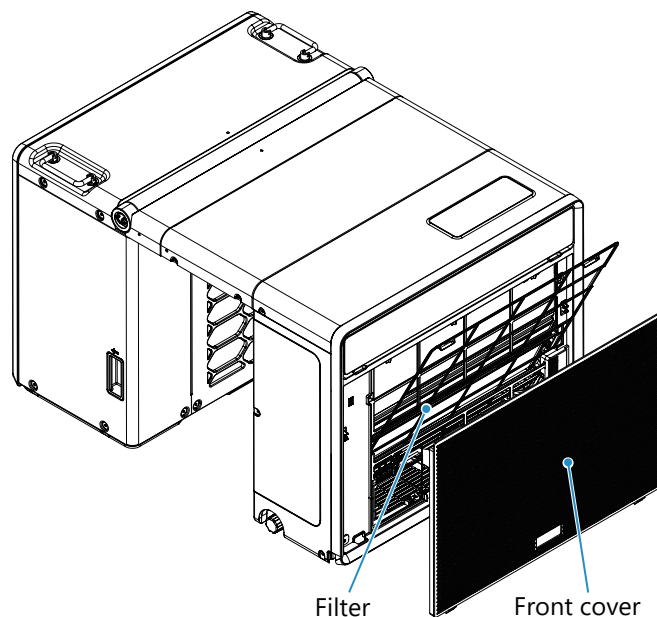
## Air Filter Cleaning

The air filter should be checked at least once every two weeks to see if cleaning is necessary. Trapped particles in the filter can build up and reduce performance

1. Remove the front cover on the indoor side of the unit.
2. Grasp the filter by the center and pull up and out.
3. Wash the filter using warm water. Rinse filter thoroughly.
4. Gently shake excess water from the filter. Be sure the filter is thoroughly dry before replacing it.
5. Instead of washing, you may also vacuum the filter clean.

### NOTE

Never use hot water over 104°F (40°C) to clean the air filter. Never attempt to operate the unit without the air filter.



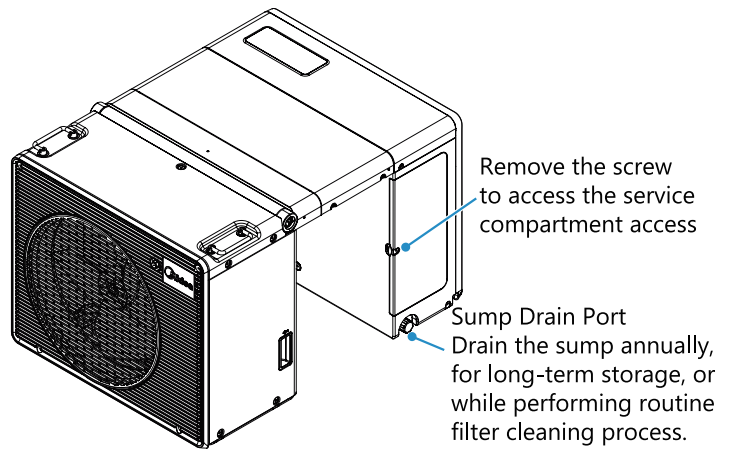
## Cabinet Cleaning

1. Be sure to unplug the unit to prevent shock or fire hazard. The cabinet and front may be dusted with an oil-free cloth or washed with a cloth dampened in a solution of warm water and mild liquid dishwashing detergent. Rinse thoroughly and wipe dry.
  - Never use harsh cleansers, wax, or polish on the unit.
  - Be sure to wring excess water from the cloth before wiping around the controls. Excess water in or around the controls will cause damage to the unit.
2. Plug in the unit.

# Pump Filter Cleaning

The pump filter screens should be cleaned and the sump drained every 6 months by qualified service personnel, or if the EH4b or EH0E error codes are displayed on the UI.

1. Turn off the unit. Place a bucket under the sump drain port, remove the port, and drain the sump.
2. Remove the service panel on the left side of the unit. Remove the filter screens by grabbing each screen by the plastic frame and pulling it up.
3. Rinse the pump filter screens with warm water to remove debris. You can also wipe the screen with a clean, wet cloth to remove any dust or debris.

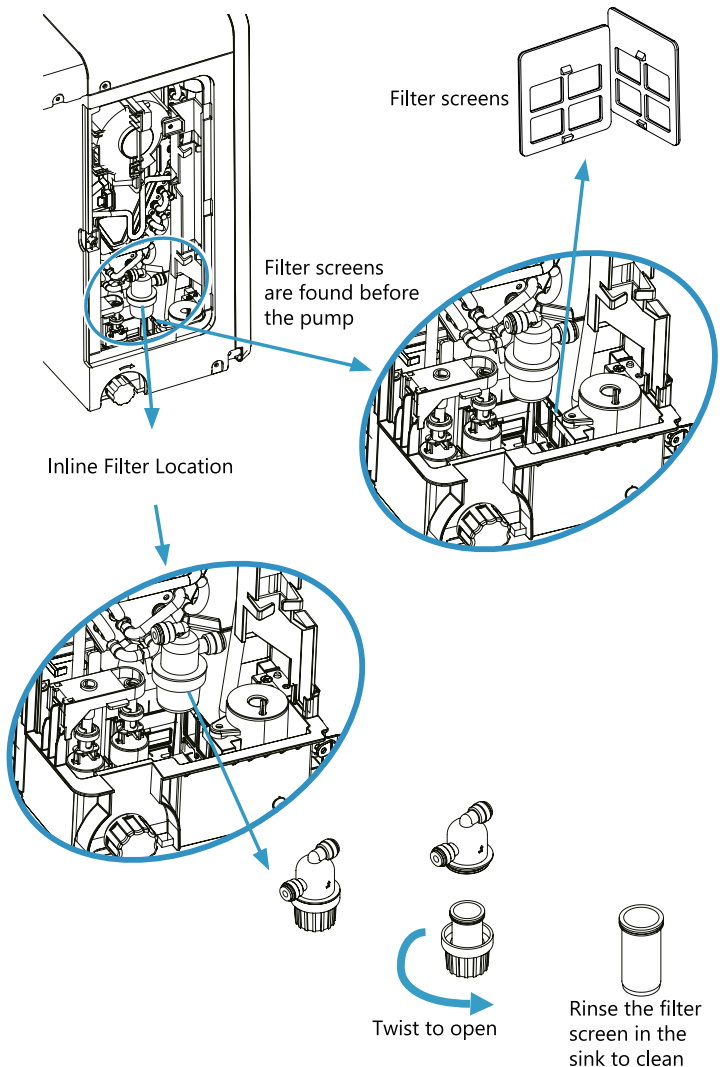


## NOTE

If the pump is running continuously or excessive noise from the pump is heard, drain the sump, remove, clean, and reinstall filter screens. Ensure error codes are cleared.

The inline filter should be cleaned once a year by qualified service personnel, or if the EH4b or EHOE error codes are displayed on the User Interface.

1. Turn off the unit. Place a bucket under the sump drain port, remove the port, and drain the sump.
2. Remove the service panel. The inline filter can be found inside the service compartment.
  - There is no need to remove the tubing from either side of the filter.
3. Open the filter housing by twisting the bottom half counterclockwise, taking care to note that there may be residual condensate in the housing.
4. Remove the filter screen and rinse the screen and housing in a sink to clear any debris that might have collected.
5. Reinstall the filter screen into the housing and reinstall the housing, twisting firmly.



## NOTE

The filter may be rotated upside down in the compartment of the unit. When referencing the cleaning instructions, note the "top" of the filter as the end containing the tubing connections, and the "bottom" as the free end.

# Troubleshooting

Before calling for service, review this list. It may save you time and expense. This list includes common occurrences that are not the result of defective workmanship or materials in this appliance.


Problem	Solution
The unit does not start.	The wall plug is disconnected. Push the plug firmly into the wall outlet.
	The circuit breaker tripped. Reset the circuit breaker.
	Check if the light on the plug is on. If it is off, press the RESET button.
	The power is OFF. Turn the power ON.
	The unit turned off and then on quickly. Turn the unit off and wait 3 minutes before restarting.
The air from the unit does not feel cold enough.	Room temperature below 62°F (17°C). Cooling may not occur until room temperature rises above 62°F (17°C).
	The temperature sensor behind the air filter is touching the cold coil. Try to move it so it does not contact the cold coil.
	Reset to a lower temperature.
	The compressor shuts off by changing modes. Wait approximately 3 minutes and listen for the compressor to restart when set in Cool mode.
	Check for potential obstructions blocking the outdoor intake/exhaust. Clear any obstructions.
The air from the unit does not feel warm enough.	Outside temperature above 75°F (24°C). Heating may not occur until the outdoor temperature falls below 75°F (24°C).
	The temperature sensor behind the filter is touching the hot coil. Try to move it so that it does not contact the hot coil.
	Reset to a higher temperature.
	The compressor shuts off by changing modes. Wait approximately 3 minutes and listen for the compressor to start when set in Heat mode.
	Check for potential obstructions blocking the outdoor intake/exhaust. Clear any obstructions.
Unit cooling, but the room is too warm - ice forming on the cooling coil behind the air filter.	Outdoor temperature below 64°F (18°C). To defrost the coil, set it to FAN ONLY mode.
	The air filter may be dirty. Clean filter. Refer to the Care and Cleaning section. To defrost, set to FAN ONLY mode.
	The thermostat is set too cold for night-time cooling. To defrost the coil, set it to FAN ONLY mode. Then, set the temperature to a higher setting.
Unit cooling, but the room is too warm - NO ice forming on cooling coil behind air filter.	Dirty or restricted air filter. Clean filter. Refer to the Care and Cleaning section. To defrost, set to FAN ONLY mode.
	The temperature is set too high; set the temperature to a lower setting.
	Air directional louvers are positioned improperly. Position louvers for better air distribution.
	The front unit is blocked by drapes, blinds, furniture, etc. - restricting air distribution. Clear obstruction in front of unit.
	Any open doors, windows, or vents may allow cold air to escape. Close any doors, windows, or vents.
	The room may be too warm. Allow additional time to remove "stored heat" from walls, ceiling, floor, and furniture.

Problem	Solution
The unit is heating, but the room is too cold.	Ice forms on the outdoor coil. Allow the unit to go through the automatic defrost cycle. Listen for a "click" that indicates the unit has entered a defrost cycle. The defrost cycle will run for 15 minutes or until the coil has been defrosted
	The air filter may be dirty. Clean filter. Refer to the Care and Cleaning section.
	The temperature is set too low; set the temperature to a higher setting.
	Air directional louvers are positioned improperly. Position louvers for better air distribution.
	The front of the unit is blocked by drapes, blinds, furniture, etc. – restricts air distribution. Clear obstruction in front of the unit.
	Any open doors, windows, or vents may allow warm air to escape. Close any doors, windows, or vents.
	The room may be too cold. Allow additional time for heat to be absorbed by walls, ceiling, floor, and furniture.
The unit turns on and off rapidly.	Dirty air filter- air restricted. Clean air filter.
	The outside temperature is extremely hot. Set the FAN speed to a higher setting to bring air past the cooling coils more frequently.
	Check for potential obstructions blocking the outdoor intake/exhaust. Clear any obstructions.
Noise when the unit is heating or cooling.	Air movement sound. This is normal. If too loud, set to a slower FAN setting.
	Window vibration - poor installation. Refer to the installation instructions or check with the installer.
Humming noise heard from inside of the service panel.	Filter screens may require cleaning. Turn off the unit and remove any debris from the pump filter screens following the instructions in the "Cleaning And Maintenance" section. Reinstall filter screens before starting the unit.
The indoor pump runs continuously.	Filter screens may require cleaning. Turn off the unit and remove any debris from the pump filter screens following the instructions in the "Cleaning And Maintenance" section. Reinstall filter screens before starting the unit.
Water dripping OUTSIDE when the unit is cooling.	The unit removes a large quantity of moisture from the humid room. This is normal during excessively humid days
Water spraying OUTSIDE when the unit is heating.	Unit removing condensate collected from defrost cycles. This is normal operation in heating mode.
The room too cold.	The temperature is set too low. Increase the temperature setting.
The room is too warm.	The temperature is set too high. Decrease the temperature setting.
Noise when the unit starts.	A high-pitched noise may occur for 3 seconds when the unit is turned on or a few minutes after the mode is changed due to the compressor starting. This is normal.
"Click" sound in heating mode.	A "click" may be heard periodically when the unit is in heating mode, at the beginning of each defrost cycle. This is normal.
Outdoor unit water level switch fault.	Please restart the machine. If the fault code still appears, please contact a qualified professional for repair.

# Error Codes

Error codes	Description
EH00	Display board / User Interface error
EH03	Indoor fan speed out of range
EC07	Outdoor fan speed out of range
EC51	Main board error
EC52	Outdoor coil temperature sensor (T3) error
EC53	Outdoor air temperature sensor (T4) error
EC54	Compressor temperature sensor (TP) error
EH60	Room air temperature sensor (T1) error
EH61	Indoor coil temperature sensor (T2) error
EH0b	Communication error between main board and display board
EL0C	Refrigerant leak detection
PC01	Over or under voltage protection
PC04	Inverter compressor drive error
EH4b	Indoor water system error – low level float switch
EC81	Outdoor water system error – low level float switch
EH0E	Indoor water system error – high level float switch
EC80	Outdoor water system error – high level float switch

## Trademarks Copyrights & Legal Statement

 Midea logo, word marks, trade name, trade dress, and all versions thereof are valuable assets of Midea Group and/or its affiliates ("Midea"), to which Midea owns trademarks, copyrights, and other intellectual property rights, and all goodwill derived from using any part of a Midea trademark. Use of Midea trademark for commercial purposes without the prior written consent of Midea may constitute trademark infringement or unfair competition in violation of relevant laws. This manual is created by Midea and Midea reserves all copyrights thereof. No entity or individual may use, duplicate, modify, distribute in whole or in part this manual, or bundle or sell with other products without the prior written consent of Midea.

All the functions and instructions described were up to date at the time of printing this manual. However, the actual product may vary due to improved functions and designs.

## Data Protection Notice

For the provision of the services agreed with the customer, we agree to comply without restriction with all stipulations of applicable data protection law, in line with agreed countries within which services to the customer will be delivered, as well as, where applicable.

Generally, our data processing is to fulfill our obligation under contract with you and for product safety reasons, to safeguard your rights in connection with warranty and product registration questions. In some cases, but only if appropriate data protection is ensured, personal data might be transferred to recipients located outside of the European Economic Area.

Further information is provided upon request. You can contact our Data Protection **MideaDPO@midea.com**. To exercise your rights such as the right to object to your personal data being processed for direct marketing purposes, please contact us via **MideaDPO@midea.com**. To find further information, please follow the QR Code.



The design and specifications may change without prior notice in order to enhance the product. For detailed information, please consult your sales agency or the manufacturer. Any updates to the manual will be posted on the service website, so be sure to check for the latest version.

## **Important!**

### **Product Warranty Information**

The Warranty Registration below is a requirement to print a warranty certificate. You're not mandated to register your products to enjoy the Midea Standard Warranty; however, registration is highly recommended. Registering your warranty within 60 days ensures easy access to support and service when needed.

#### **United States**



<https://www.mideacomfort.us/registration.html>

#### **Canada**



<https://www.mideacomfortna.ca/registration.html>